

Studio Dobby Loom

User's Manual

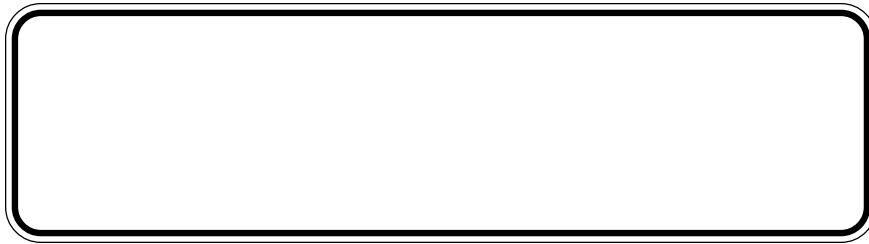

AVL Looms
3851 Morrow Lane, Suite 9
Chico, CA 95928-8305

Customer Service: 888 893-0913

Sales: 800 626-9615
EM: info@avlusa.com



Version 3.0
January 2002

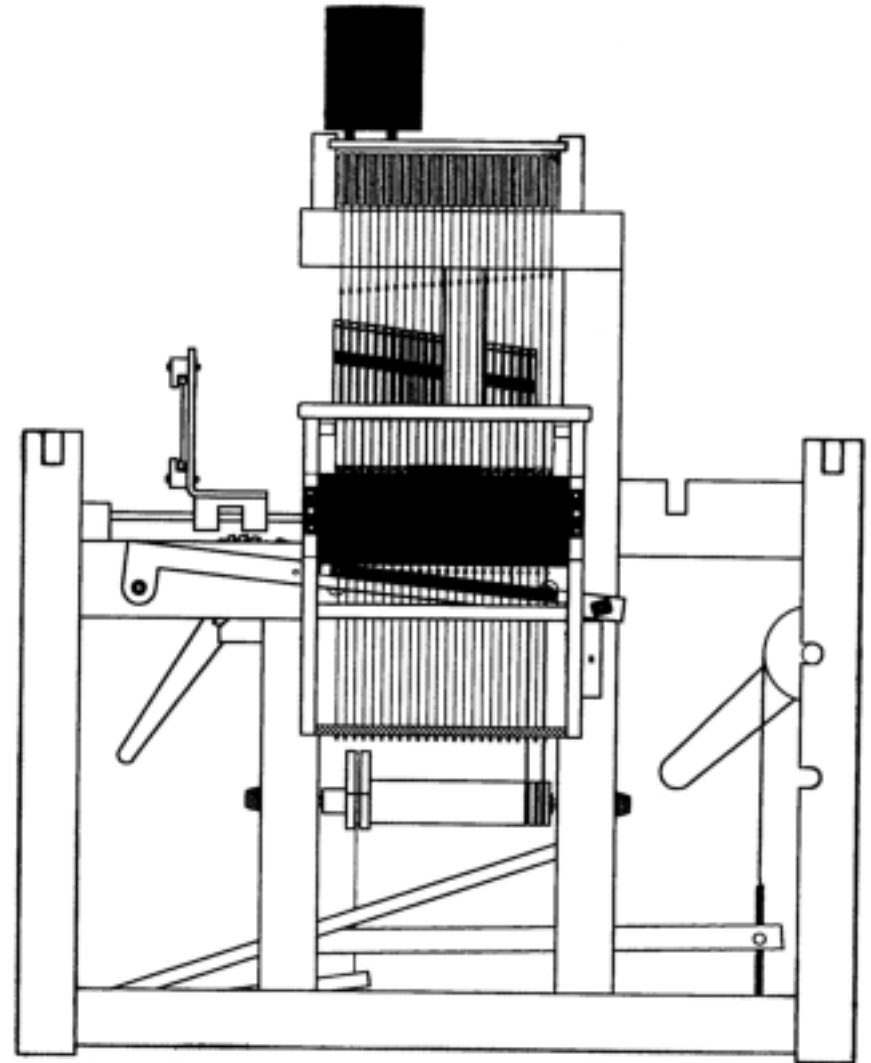

TABLE OF CONTENTS

INTRODUCTION

- About AVL 1-1
- Design Concept 1-2

SET UP (Assembled Loom)

- Receiving Your New Loom 2-1
- Shipping Damage 2-1
- United Kingdom Customers 2-2
- Unpacking 2-2

ASSEMBLY (Knocked Down Loom)

- Before You Begin 3-1
- Tools 3-2
- Side Frames 3-2
- Dobby Cam Cylinder 3-8
- Cross Members 3-10
- Brake Pedal 3-14
- Sliding Beater 3-18
- Swinging Beater 3-20
- Dobby Head 3-20
- Texsolv (poly) Harnesses 3-22
- Warp Beam(s) 3-24
- Second Warp Beam Brackets 3-26
- Brake Cable 3-27
- Treadle Cables 3-28
- Shelf 3-30
- Compu-Dobby 3-31

WEAVING

- Warping the Plain Beam 4-1
- Warping Two Plain Beams 4-7

- Warping the Sectional Beam 5-1
- Setting Up the Tension Box 5-4
- Combining Sectional and Plain Warping 5-11

- Threading, Sleying, and Tying On 6-1

LOOM CONTROLS

- Right Treadle 7-1
- Left Treadle 7-1
- Cam Cylinder 7-2
- Brake System 7-2
- Cloth Storage System 7-3
- Removable Breast and Separation Beams 7-3
- Sliding Beater 7-3
- Swinging Beater 7-4
- Sectional Beam 7-4
- Plain Beam 7-4
- Dobby Head and Compu-Dobby 7-4
- Spring Levers 7-5
- Harnesses 7-6

MAINTENANCE

8-1

AVL CUSTOMER SERVICE

9-1

Warranties

9-1

AVL Returns Policy

9-1

AVL Compu-Dobby Loaner Service

9-2

INTRODUCTION

ABOUT AVL

AVL Looms has been in the business of designing and building some of the world's finest handweaving looms since 1976. Jim Ahrens, the "A" in AVL, was the seminal mind behind our basic design concept. His immeasurable contributions to handweaving are the products of a keen mind coupled with his training as an engineer, in-depth historical research, and constant application. Now in his nineties, Jim maintains an active collaboration with the company from his home in Utah, where he resides with his wife Ethel.

Over the years many people, from customers to staff, have offered suggestions that have helped us improve our products. Once known for our production looms, AVL has broadened its line considerably and we now offer customers a full spectrum of fine weaving equipment, ranging from our small Home Looms, to our Industrial Dobby Looms, Rug Looms, and Jacquards.

SDL DESIGN CONCEPT

In 1996 we began, in earnest, to design a loom that would meet the very specific needs of university weaving programs and small design studios. According to our research, such a loom would need to be small, extremely robust, and very basic in its mechanical systems. However, it would still need to offer harnesses in sufficient number to handle complex weaving structures and had to be computer capable.

The result of that process is the loom you have before you. It is in all respects an *Ahrens* loom, however, it benefits significantly from suggestions made by noted weaver and teacher, Ann Sutton, from other weaving instructors, and from the work of our own very capable design staff.

The Studio Dobby Loom is not a production loom. It was designed from the ground up as an *instructional* loom that might serve equally well as a *sampling* loom. Such mechanisms as Automatic Cloth Advance and Auto Warp Tensioning, extremely valuable in a production environment, have been replaced by systems more appropriate in an instructional or design context, where speed is less an issue, but ease of maintenance is more. We think you'll be delighted with the functionality afforded by this design.

SET UP

RECEIVING YOUR NEW LOOM

If your loom was assembled by AVL it will have arrived in a single large box. Looms delivered outside the continental U.S. will probably be further contained within a protective framework. Accessories too large to include with the loom will be located in supplementary boxes. Looms delivered knocked down will arrive in several large and small boxes.

Please confirm that you received the number of boxes indicated on your copy of the Bill of Lading. If not, best call the delivery company, you may have parts still roaming the countryside.

SHIPPING DAMAGE

Rarely is a loom damaged in shipping, however, if you do discover damage please call the delivery company immediately. Then call us at 530 893-4915.

Freight haulers are not agents of AVL and only the consignee, the customer, *you*, may file a damage claim. It's best if you save your packing materials; some freight companies wish to examine them as part of their claims process.

AVL will immediately replace the damaged parts and invoice you for them. You, in turn, should present the bill to the freight company. They, in turn, will pay it (they always have!). It's inconvenient for all of us, but really not too troublesome and we'll make an extra effort to get your replacements to you quickly.

ASSEMBLED OR NOT

If you purchased your loom pre-assembled, please proceed now to the instructions provided in the next section: *Unpacking an Assembled Loom*. If you requested your loom knocked-down, move on to *Assembly* on page 3-1.

UNITED KINGDOM CUSTOMERS

Your loom will have been packaged somewhat differently than those shipped to other locales. Essentially, we have already assembled your side frames. This means that you will NOT have a package of side frame hardware. You should begin assembling your loom at page 3-8, **Install the Compu-Dobby Cylinder**. However, we do urge you to read the introductory material on pages 3-1 and 3-2 before you proceed to page 3-8.

UNPACKING AN ASSEMBLED LOOM

Again, if we assembled your loom at our facility, it will arrive wholly or mostly in one box.

- Cut and remove the plastic strapping.
- Use a screwdriver or other flat implement (not a knife, please!) to separate the top and bottom trays from the cardboard sides.
- Pull off the cardboard top cap.
- Lift the sides up and over the loom (they are joined into a single piece).
- Untape and remove any ancillary boxes. We try always to leave a tab at the end of each piece of tape, so you can pull it off rather than cut it.
- Get a helper to aid you in lifting the loom off its plywood skids.
- Move the loom to its permanent location.
- Carefully untape the beater, harnesses, and all other mechanisms.
- Replace any cables that have obviously been dislodged.
- Carefully check the loom for damage.

Once you've installed the Compu-Dobby your loom will be weaving ready. We'll explain the Compu-Dobby installation later, but first let's make a quick inspection. You may wish to consult the Parts List in the appendix if any of our part names are unfamiliar to you.

- Remove the Shelf Retention Pin at the rear of the Harness Pulley Supports. Slide the shelf out and set it aside.
- Working down from the top of the loom, please verify that:
 - All Harness Cables are located in their pulleys.
 - All Harnesses are attached to Harness Cables.
 - Dobby Cables are not tangled in the Dobby Head.
 - Harness Springs are connected between Spring Levers.
 - Treadle Cables are strung over pulleys.
 - Treadles operate freely.

- Sliding Beater (if equipped) operates smoothly.
- Swinging Beater (if equipped) swings smoothly, without interference from adjacent parts.
- Cloth Advance Handle engages with Cloth Storage Beam Ratchet and advances beam.
- Depressed Brake Pedal(s) releases tension on cables.

Replace the shelf.

ASSEMBLY

BEFORE YOU BEGIN

Let us offer a few words of encouragement. You may be a little intimidated by the prospect of assembling your new loom — perhaps you don't consider yourself very mechanical or are afraid you'll make some horrendous, irremediable error that will finally prove to the world that you are a complete technical incompetent. Relax; you do many things in your daily life that are more complicated and technically challenging than the thing you're about to do. If at any point you become disoriented, unsure, or outright confused, call us (our dime by the way) at 888 893-0913. We're here to help. If you're nervous that you might be asking a dumb question, console yourself with the knowledge that with absolute certainty someone else has already asked it. The only dumb question, of course, is the one not asked. Besides, we know you're brilliant — you bought an AVL!

There is a definite advantage in assembling your own loom. You'll come to know it very well, sooner than you otherwise would, and the better you know your loom, the better you'll be able to use and maintain it.

Tools:

First, you'll need tools:

- Hammer
- Socket Wrench with 1/2", 7/16" and 9/16" sockets.
- Large Bladed Screwdriver
- Medium Phillips Screwdriver
- Large Phillips Screwdriver
- Scissors
- Crescent Wrench
- Occasional Extra Pair of Hands

Packed with your hardware are a few additional tools that you may not have. They'll be there when you need them.

Once you've gathered your tools, open all the boxes and lay the contents out just as you find them. *Please DO NOT remove the tape from any of the components until we tell you.* Please, too, leave the hardware bags unopened until they are required. Clear away all your packing materials — they'll just be in the way. It's best if you keep your work area as organized and free of clutter as possible.

You'll need a space about 5' x 5' to assemble your loom. In addition, a conveniently located desk or table will come in very handy for several of the operations.

Depending on your particular style of work, the entire assembly operation will take between three and eight hours.

LEFT AND RIGHT SIDE FRAMES COME TO YOU PRE-ASSEMBLED (see Figures 1 and 2)

LEFT SIDE FRAME

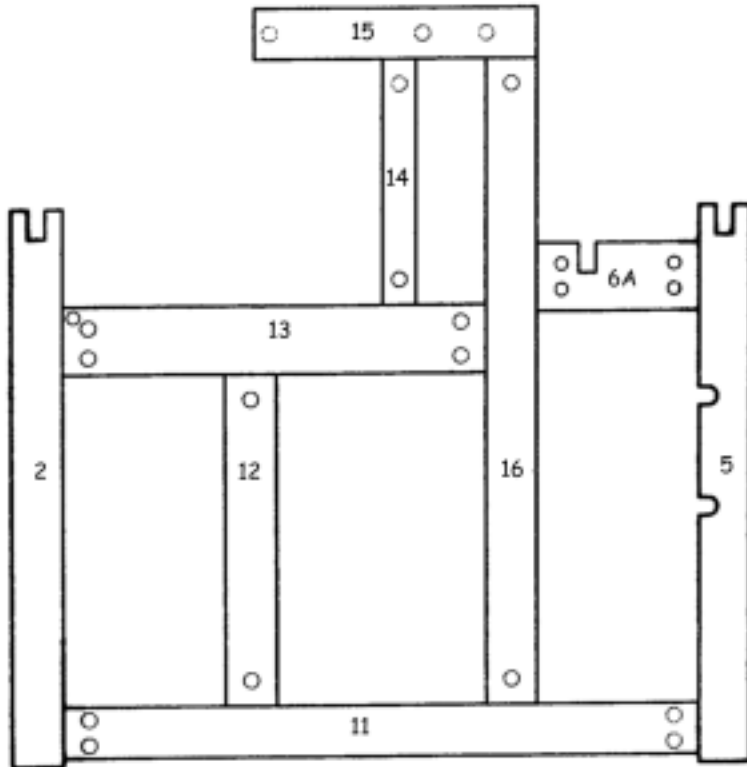

- 2- Front Vertical
- 5- Rear Vertical
- 6A- Mid Rear Horizontal (Left)
- 11- Bottom Horizontal (Left)
- 12- Mid Vertical (Left)
- 13- Mid Front Horizontal (Left)
- 14- Top Horizontal Support (Left)
- 15- Top Horizontal (Left)

FIGURE 1

ABOUT THOSE NUTS AND BOLTS

NOTE: Given the limited space provided by the nut access holes, it's a little challenging getting the nuts onto the bolt ends. It gets easier with practice. You'll find it helpful to push each bolt in just until it just appears in the access hole. Move the nut into position over the end of the bolt and back it with your finger. Push the bolt in a little further and seat the nut. Slowly turn the bolt clockwise and when the nut engages, tighten it most, but not all, the way down. It's best to leave everything a little loose at first.

Finally, if your fingers are just too big to comfortably manipulate the nut, try backing it with a flat bladed screwdriver.

ACCESS HOLE DETAIL

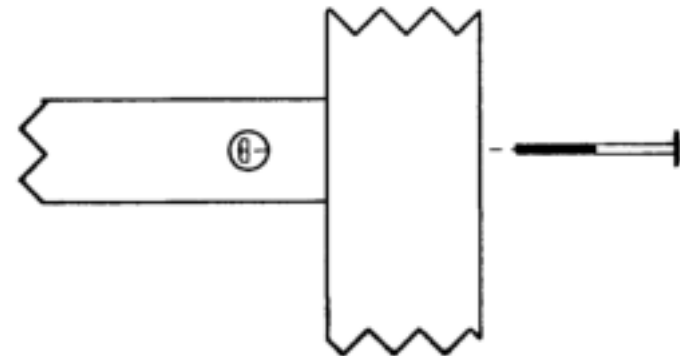

RIGHT SIDE FRAME HARDWARE

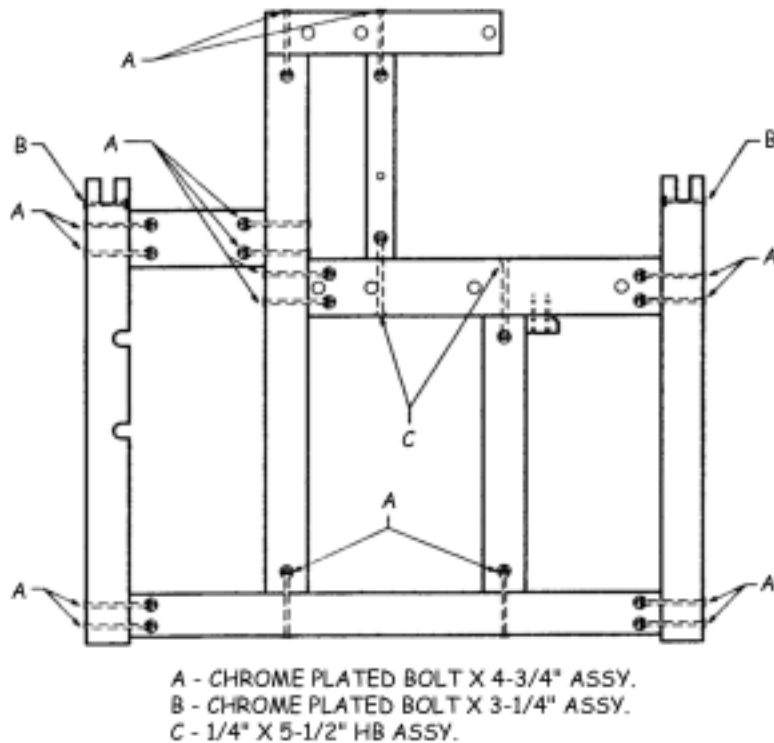

FIGURE 2

INSTALL THE DOBBY CAM CYLINDER

The Dobby Cam Cylinder provides mechanical advantage to the right treadle, greatly reducing the amount of effort required for harness lifting.

- 1.) This assembly is supported by an axle that spans parts #3 and #4.
- 2.) Locate the assembly and withdraw the axle. It should slide out effortlessly.

NOTE: Make sure there isn't anything (string, tape) lodging the axel in the cam.

- 3.) Insert the axle from the left side, into the mounting hole in part #3. Push it about half way through the hole.
- 4.) Rotate #3 about 20 degrees so that the free end of the axle points to the outside of the loom.

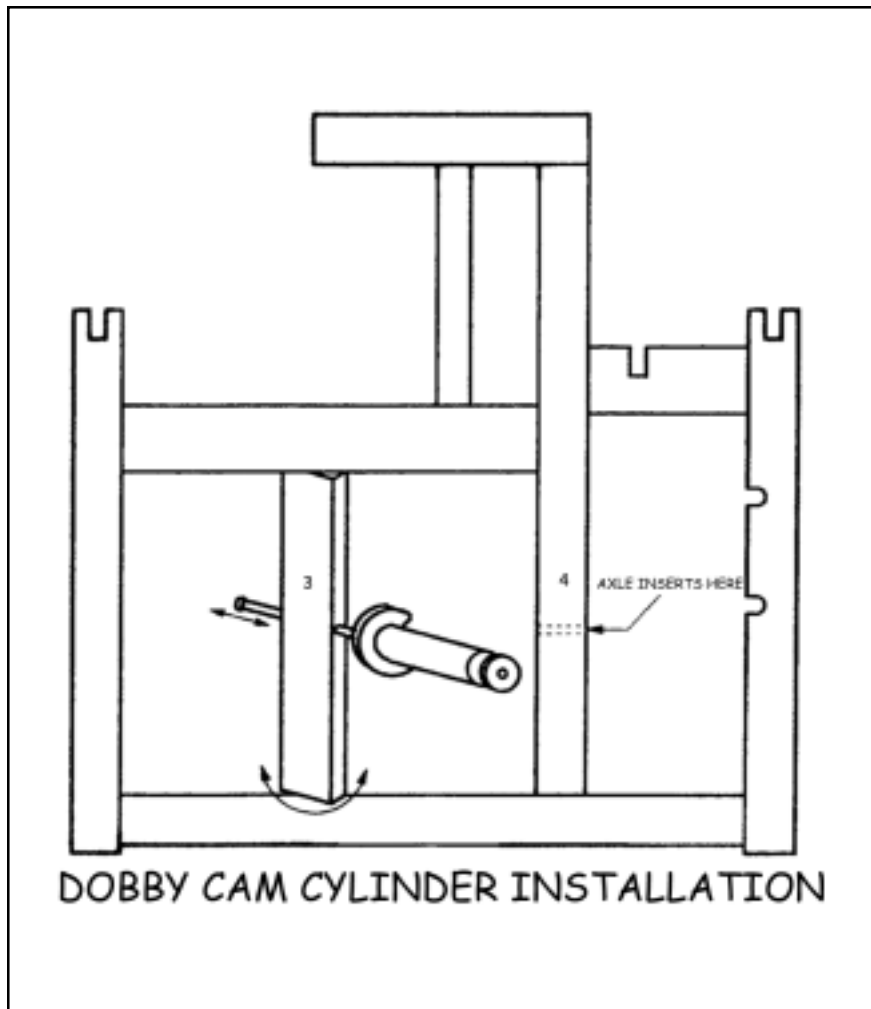

- 5.) Thread the Cam Cylinder and wooden pulley back onto the axle.
- 6.) Pivot #3 back into position so that the free end of the axle now points to the opposite mounting hole in #4.

- 7.) Push the axle through the hole in #4 until the blank end comes out the other side.
- 8.) Check the position of the Cam Cylinder and pulley against the diagram below. Looks the same? Good!

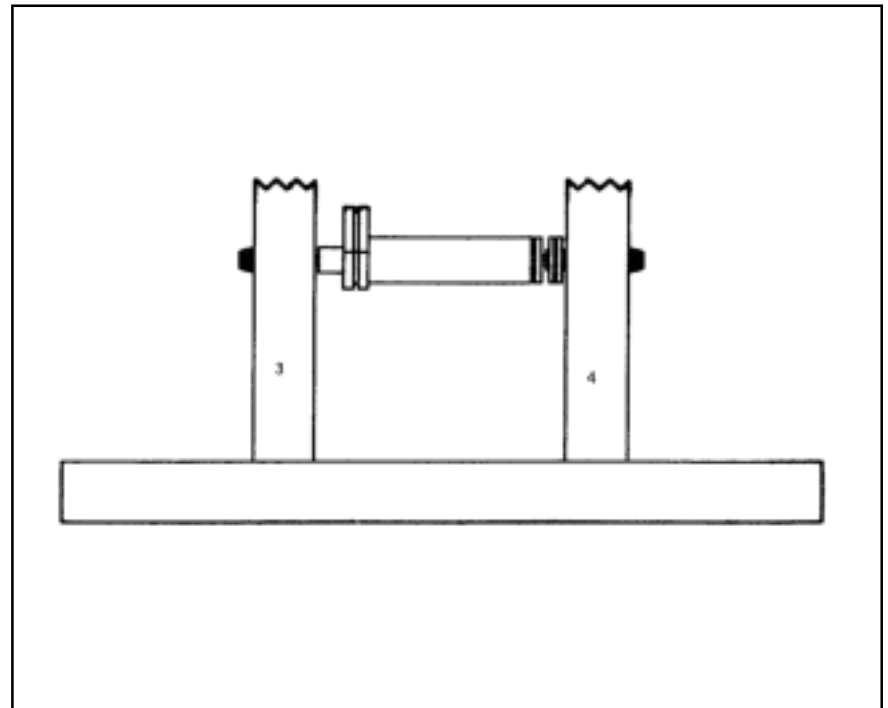

- 9.) Find the black plastic cap provided in the hardware bag. Use your hammer to drive this cap onto the end of the axle. You'll likely need that extra pair of hands to bear against the cap at the other end.

-
- 10.) Tighten the screws that secure #3. Bring the frame back to its feet and tighten the top screw.

Let's declare the side frames finished. Great time to take a moment for reflection. If your extra hands aren't otherwise occupied, you may want to invite them to remain a while longer. If they beg relief, dismiss them curtly and together we'll demonstrate just how independent you can be!

INSTALLING THE CROSS MEMBERS

In the next stage of your loom assembly, you'll attach the various members that connect the left and right side frames. We've already sub-assembled many of the components and you'll progress quickly through these operations. When done, your loom will look like a loom.

The tools you already have at hand will suffice.

- 1.) Please locate:
 - Lower Back (#17)
 - Cross Member Hardware Pack
- 2.) By now you know the drill. Sort the hardware.
- 3.) Select four 3-1/4" Chrome Plated bolts, with square nuts. Remove the nuts.
- 4.) Stand both side frames on their feet, about 2' apart, with their access holes facing inward. Put yourself at the front of the frames.
- 5.) Pivot each frame forward 90 degrees so that they lay on their Front Verticals (#2).

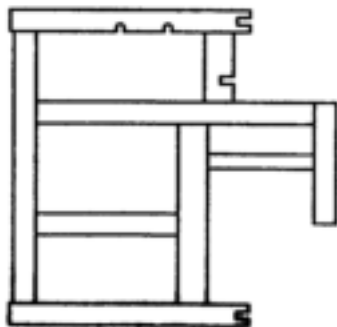
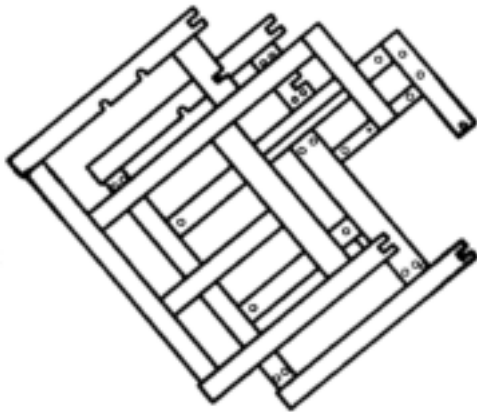
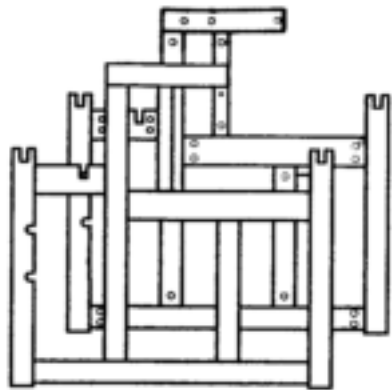

CROSS MEMBER MOUNTING HOLE LOCATIONS

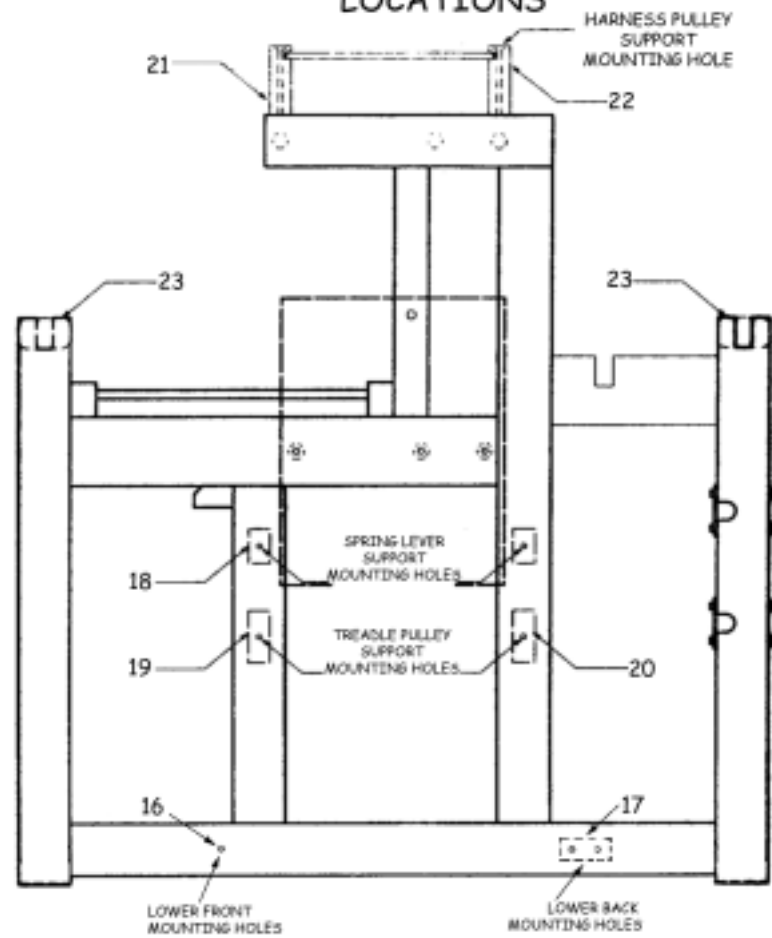

-
- 6.) Locate the mounting holes for the Lower Back in the accompanying diagram.
 - 7.) Position the four mounting bolts in their holes.
 - 8.) Bring the Lower Back into position and orient it so that the access holes are facing the floor when the loom is upright.
 - 9.) Push the bolts into the access holes at both ends of the Lower Back; add the nuts and tighten down well.
 - 10.) The frame is now self-supporting. Put it back on its feet.

INSTALL THE CLOTH STORAGE BEAM

The Cloth Storage beam **MUST** be installed at this point in the assembly process. Its axle fits into holes in the side frames and once the frames are joined further, it will be impossible to add the beam.

- 1.) Locate the beam mounting holes in each side frame. These are about 1" in diameter and lay opposite one another in the Mid Front Horizontals. They are drilled completely through the frames.
- 2.) The Cloth Storage Beam has a metal ratchet on one end. Find the beam now. Find, too, the Cloth Advance Handle and bring beam and handle to the loom.
- 3.) You'll see that the advance handle has an oblong hole at one end. Fit this hole over the cloth storage beam axle (ratchet side). Be sure that the wooden handle will point to the interior of the loom.
- 4.) Now slip both ends of the beam into their mounting holes.

- 5.) Allow the handle to rest atop the small block you previously installed in the right side frame.
- 6.) Push the side frames together. Take care not to dislodge the beam until the lower front is installed.

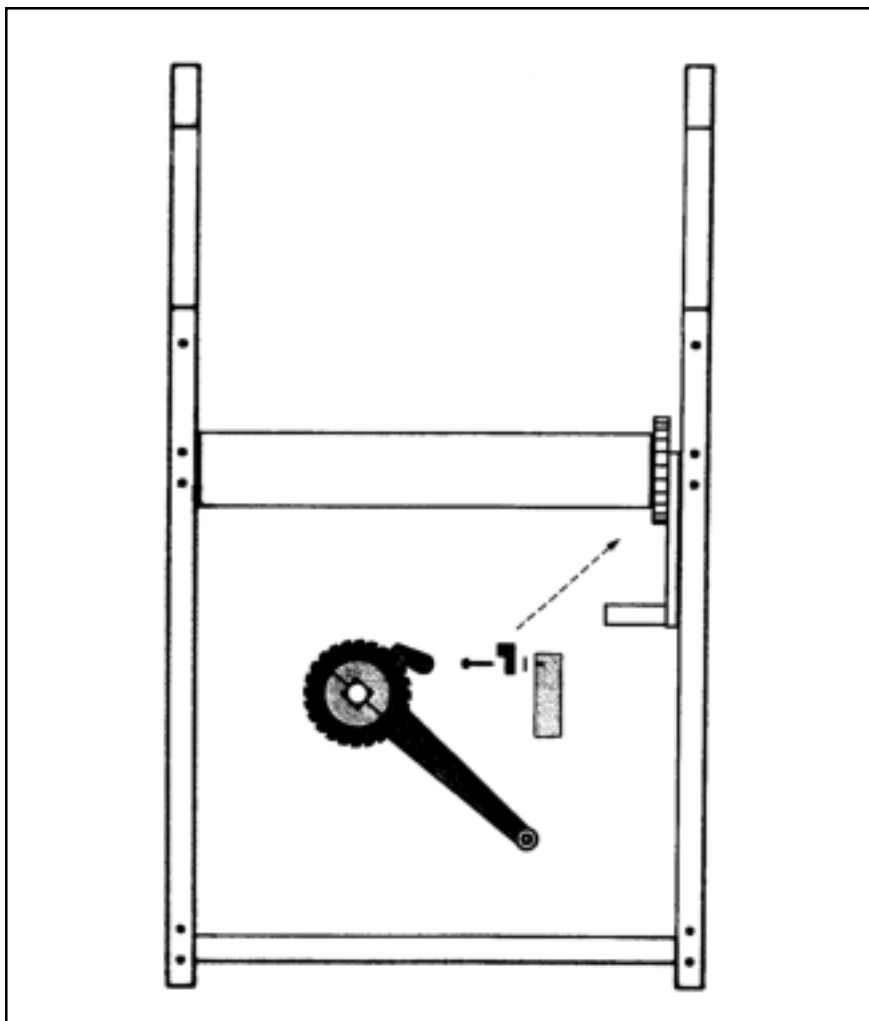

INSTALL THE LOWER FRONT ASSEMBLY

- 1.) The Lower Front Assembly consists of a cross member, treadle assembly, and treadle mounting hardware (#16, #35, #36, etc.). Find it now and bring it to the loom.
- 2.) From the treadle rod, remove the two mounting blocks. Leave the two stop collars in place on the rod. Slide the long treadle on from the left and the short treadle on from the right. Slide the mounting blocks onto the ends of the rod. Now screw the mounting blocks to the cross member.
- 3.) Select and de-nut another four attachment bolts. Identify the Lower Front mounting holes on the diagram.
- 4.) Move again to the front of the loom; this time, pivot it away from you and lay it on its Rear Verticals.
- 5.) Place the mounting bolts in the bottom holes in the Front Verticals.
- 6.) Bring the Lower Front Assembly into position. Orient it so that the longest treadle is on the left.

- 7.) Install the assembly. A bit awkward — just allow the treadles to hang.
- 8.) Leave the loom on its Verticals for now.

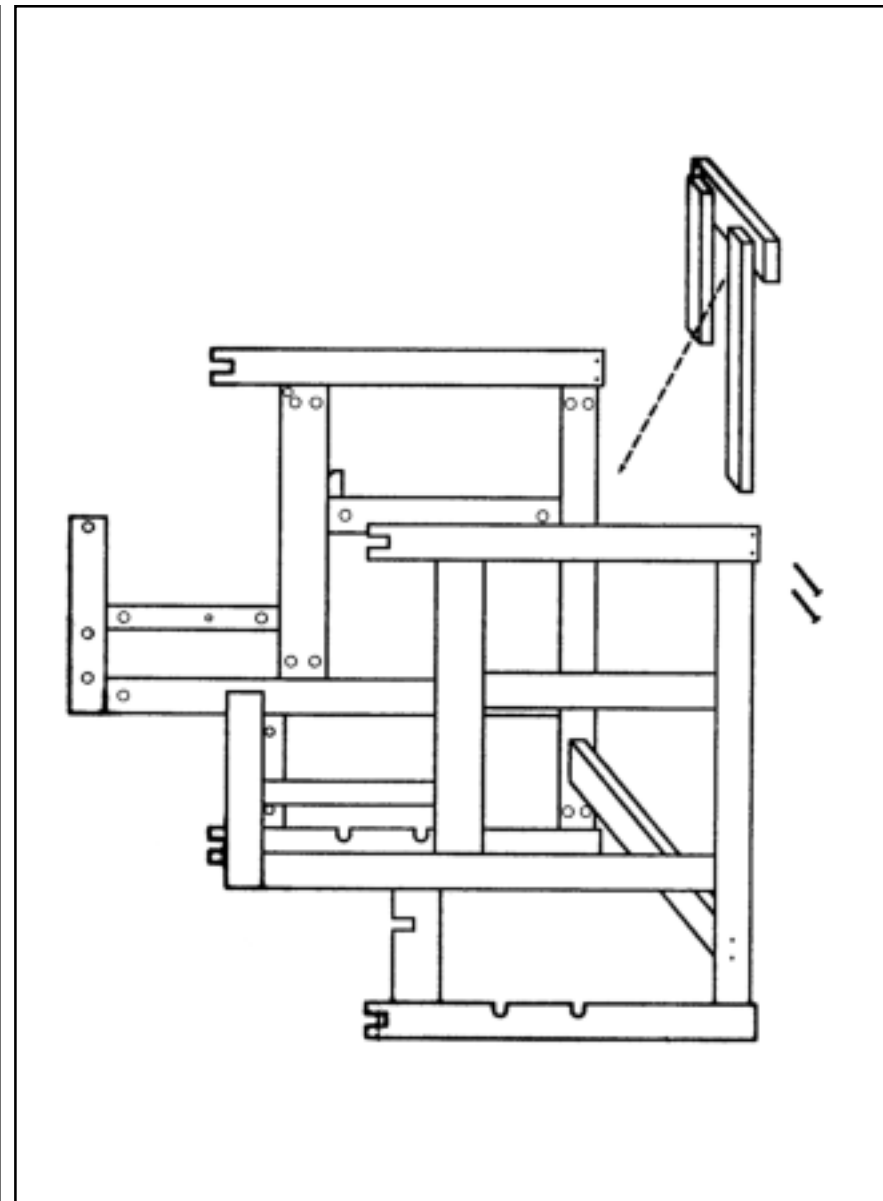

INSTALL THE BRAKE PEDAL

- 1.) If you will be using a single beam, you'll want to mount the Brake Pedal on the left side of the loom. If you have two warp beams, you'll need to mount two pedals; one left, one right.
- 2.) Please locate the Brake Pedal assembly or assemblies.
- 3.) Remove and set aside the nut, washer, and carriage bolt. Leave and the smaller bolt assembly at the end of the pedal in place.
- 4.) Find the Brake Pedal mounting hole in the diagram.
- 5.) From the outside of the Left Castle (#16), insert the carriage bolt into its hole. Use light hammer taps to seat the bolt head in the wood.
- 6.) Push the Brake Pedal onto the carriage bolt so that the longest part of the pedal is to the front of the loom. The pedal must also rest atop the metal stud you installed earlier. Add the washer (it should just fit the recess) and the nut, and snug down with a 9/16" socket.

- 7.) If you have a second pedal, mount it now to the opposite side frame.

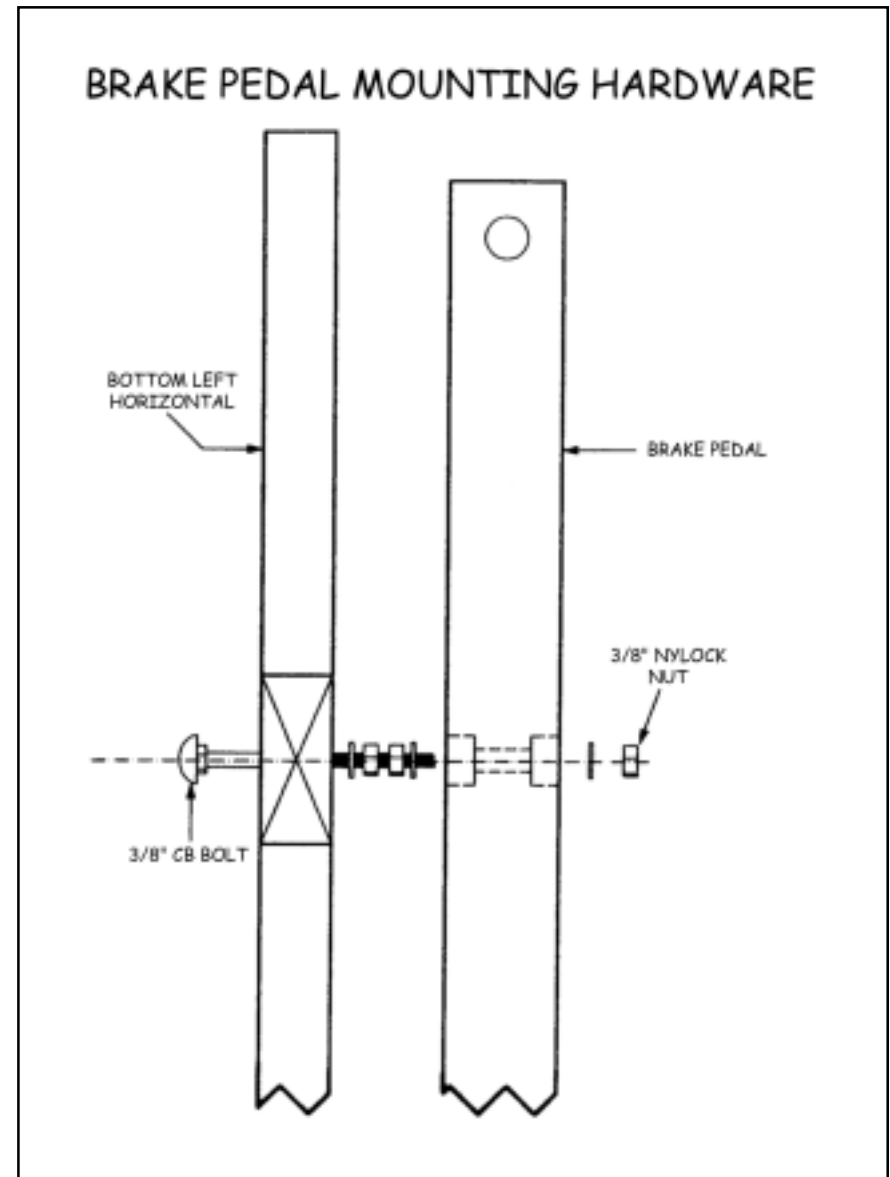

INSTALL THE TREADLE PULLEY SUPPORT ASSEMBLY

- 1.) Put the loom on its feet.
- 2.) Collect four more of your mounting bolts and relieve them of their nuts.
- 3.) Locate the Treadle Pulley Assembly and bring it to the loom (it has two cross members, two large wooden pulleys on axles, and a couple of black metal straps).

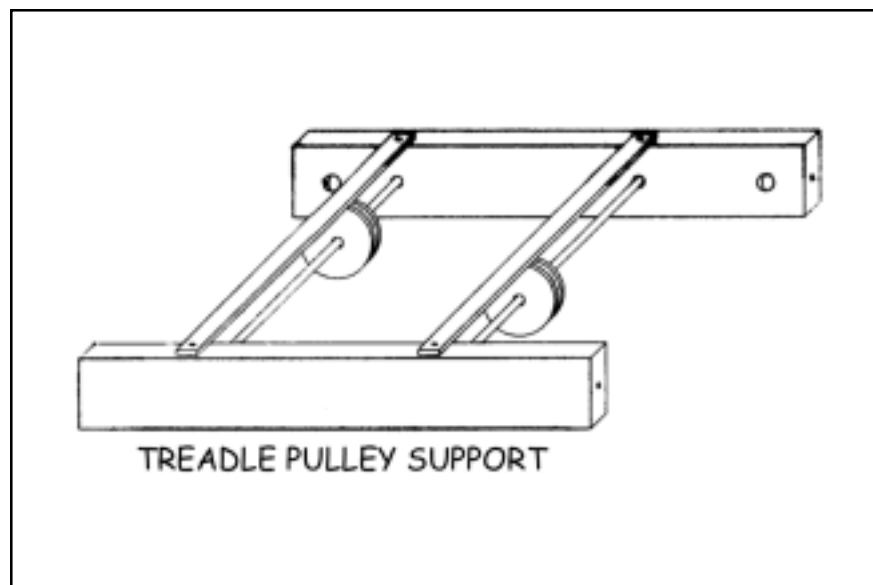

NOTE: From the front of the loom, the short side of the Treadle Pulley Support Assembly goes to the right.

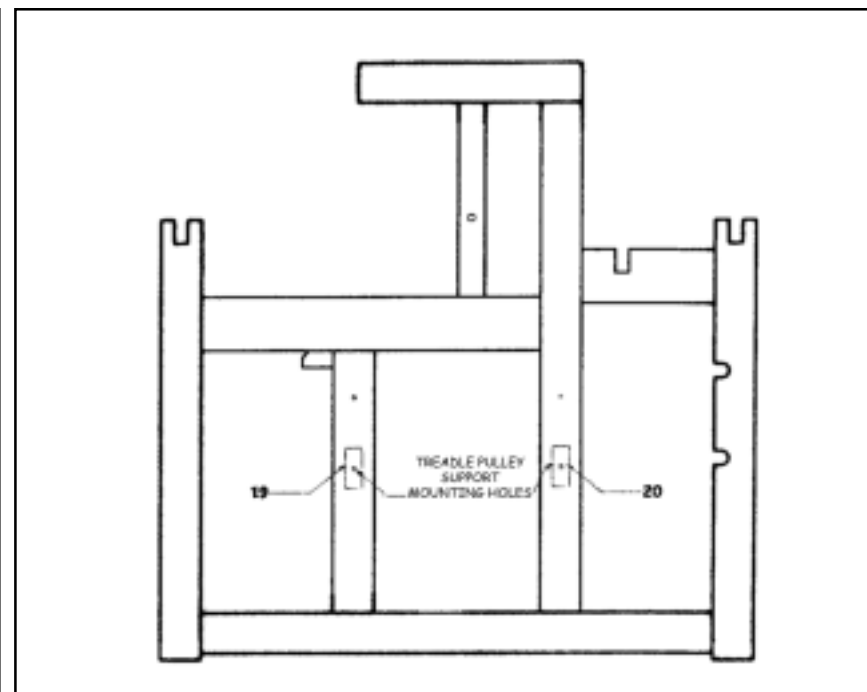

- 4.) Consult the diagram to determine the attachment location; then, locate the bolts in the frames.
- 5.) This assembly has a definite left/right, up/down orientation. The metal straps indicate the top: when in place, the right pulley is offset nearest the right side frame. That is, there is more distance between the left pulley and left side frame, than the right.
- 6.) Once you've correctly oriented the assembly, bolt it into place.

- 7.) Leave the assembly mounting bolts loose enough that you can spread the frame about 1/4". This will facilitate placement of the Spring Lever Supports.

INSTALL THE SPRING LEVER SUPPORTS

- 1.) The Spring Lever Support mounts a few inches above the Treadle Pulley Support you just installed. It again consists of two cross members and two axles, this time carrying a series of 32 or 48 hooked levers with chains. Please find it.

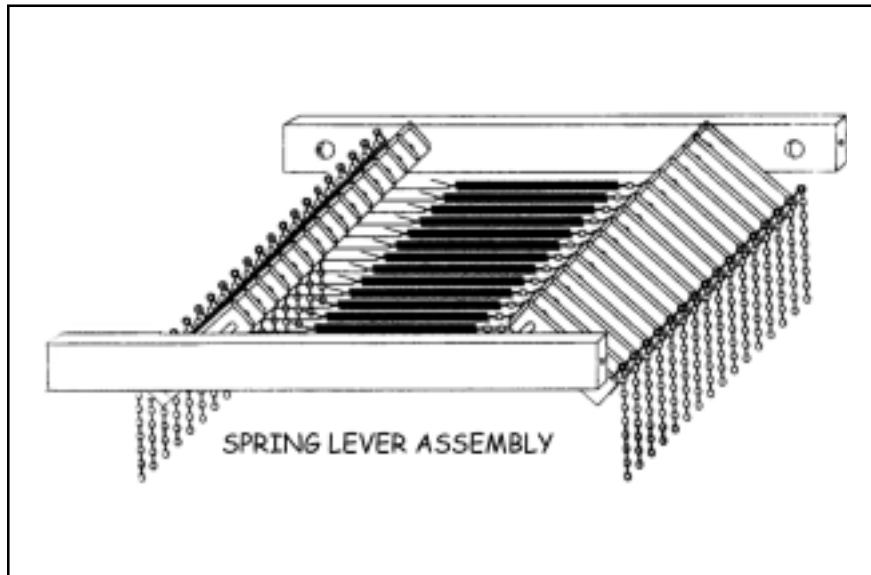

- 2.) Again, there is a definite orientation that must be observed. If you examine the assembly closely, you'll note that half of the levers on each side are shorter than the others. THE SHORT LEVERS GO TO THE FRONT! Once more, the short levers go to the front! Where do the short levers belong? In the front!!!
- 3.) Four more bolts — you know the rest. But tighten these bolts down hard. You're quickly becoming a Master Loom Builder; have you noticed? Give yourself a quick pat on the back.

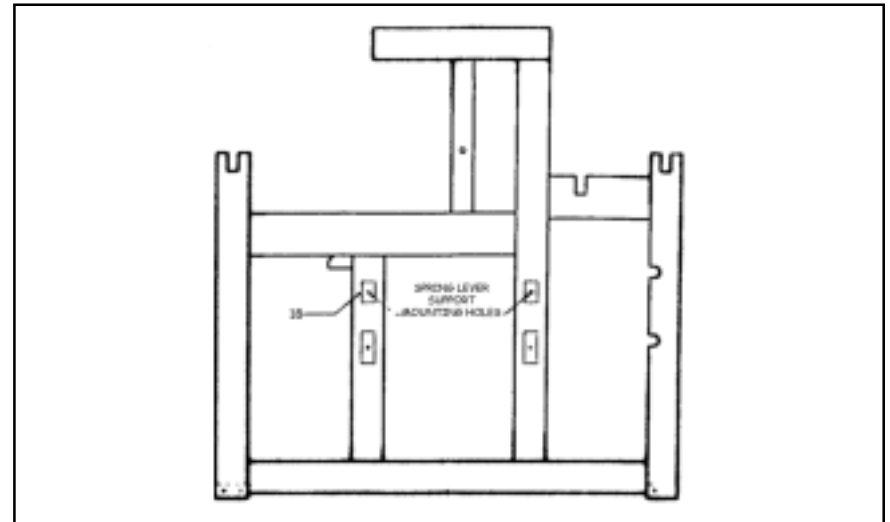

- 4.) Return now and tighten the Treadle Pulley Support bolts.

-
- 5.) Before you proceed, you'll want to neaten the Spring Levers. The **left** spring levers simply hang. Disengage the brass hooks so that they all point to the interior of the loom. The **right** levers will rest atop the right-most metal strap. Here, too, deploy the hooks so that they all point to the interior of the loom. Allow the chains to hang.

One more set of cross members and you'll be hanging the Dobby, then the beater and harnesses. Soon, you'll be finished.

INSTALL HARNESS PULLEY SUPPORT ASSEMBLY

- 1.) Locate this assembly.
- 2.) From your hardware pack, select:
 - 4 — 1/4" x 5-1/2" Flat Head Machine Screws
 - 4 — 1/4" Square Nuts
- 3.) Lay the HARNESS PULLEY SUPPORT ASSEMBLY atop the loom frame. It should overhang about 4" on the right side.

- 4.) Cut and carefully remove the packing tape.
- 5.) Align the holes in the four mounting holes in the Pulley Supports with those in the TOP HORIZONTALS.
- 6.) Insert the Flat Head Machine Screws, add the Square Nuts, and tighten.

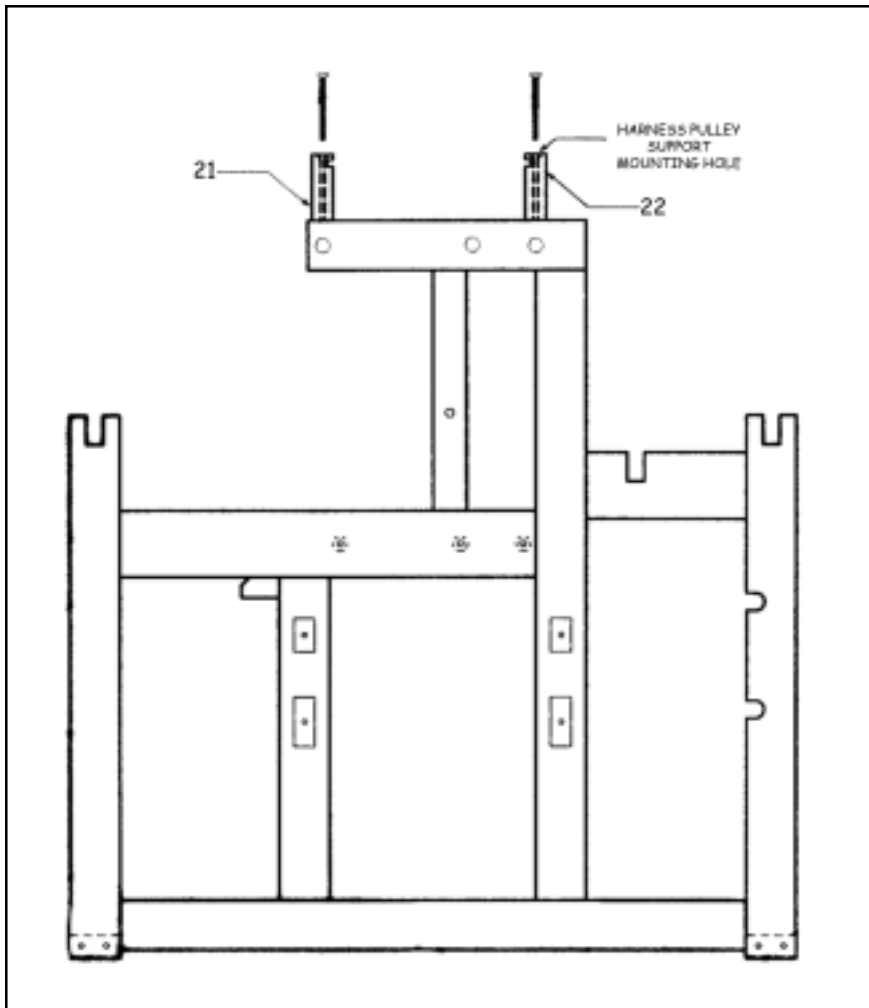

INSTALL THE BEATER ASSEMBLY

AVL provides two beater options: an overhead Swinging Beater or a rail mounted Sliding Beater. Follow those directions that are appropriate to your system. Both systems are quite easy to install.

SLIDING BEATER

- 1.) This is one of the last major assemblies, so it shouldn't be hard to find. Please bring it to the loom.
- 2.) Attached to the assembly are bags with mounting hardware. In them you will find:
 - Beater Mounting Blocks (4)
 - 3/8" x 3" Flat Head Machine Screws (2)
 - 3/8" x 6" Flat Head Machine Screws (2)
 - 3/8" Square Nuts (2)
 - 3/8" Nylock Nuts (2)
- 3.) Consult the diagram to determine the proper beater orientation.

- 7.) Take a moment to breath and appreciate your progress. You've achieved something like the pinnacle of the assembly process. Everything's down hill from here.

SLIDING BEATER ORIENTATION

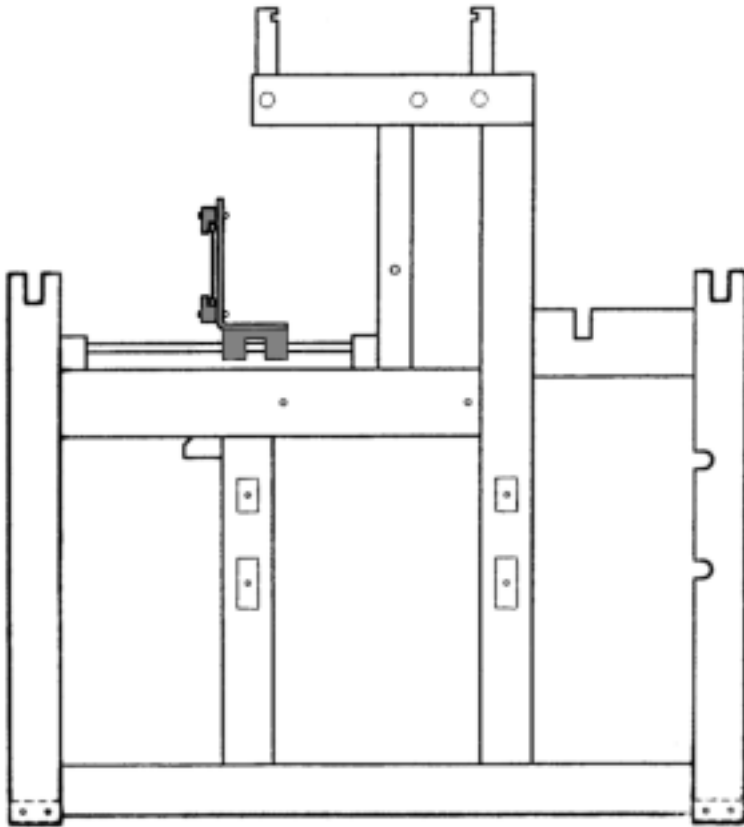

- 4.) Each Mounting Block is labeled with an identifier. Position the blocks on the ends of the Beater Slide Rods according to these identifiers. The large countersunk holes in each block should be oriented to the top.
- 5.) Drop the longer screws into the rear blocks, the shorter into the front.
- 6.) Carefully position the assembly atop the Mid Front Horizontals (# 2, #13). With a little jiggling, the screws will fall into the mounting holes.
- 7.) Apply the square nuts and tighten them most, but not all the way, down. We need to make an adjustment before you lock the beater down tight.
- 8.) Slide the beater all the way forward so that the leather bumpers are equally compressed. While holding, snug down the two front screws. (You really need your partner for this. If no one is available at this very moment, leave the beater as it is and come back to adjust it later.)

-
- 9.) Now, push the beater all the way rearward and snug down the back screws.
 - 10.) Bring the beater forward again. Check its action: is it square to the mounting blocks? If so, tighten the front screws down hard.
 - 11.) Push the beater all the way rearward and make the same check. Tighten the screws.
 - 12.) You may need to perform this back and forth action several times, making minor adjustments as you go. The point, of course, is to put the Beater Slide Axles in exact parallel.
 - 13.) When you're finished, the beater should slide easily along the full length of its travel.

INSTALL THE SWINGING BEATER

- 1.) Installing the Swinging Beater is easier than making Jello. We've already added the mounting blocks to the Front Harness Pulley Support. All you need to do is bring the assembly to the loom and drop the Hanging Arms into their slots.
- 2.) The beater may unavoidably have been put out of adjustment in shipping. If it seems so to you, loosen the attachment hardware, bring it all the way forward, hold, and retighten.

INSTALL THE DOBBY HEAD

- 1.) Find and unpack the Dobby box. It will contain:
 - Dobby Head with attached Sensor Case
 - Dobby Arm Assembly
- 2.) The Dobby Head hangs from the right side of the loom, at the mid-point on the frame.
- 3.) The accompanying diagram shows the location of the mounting holes. Note that three mounting bolts protrude from the back of the Dobby Head. If any of these have come loose, you'll need to reposition them from inside the Dobby Box. Note that the bolt heads seat in a recess in the wood.

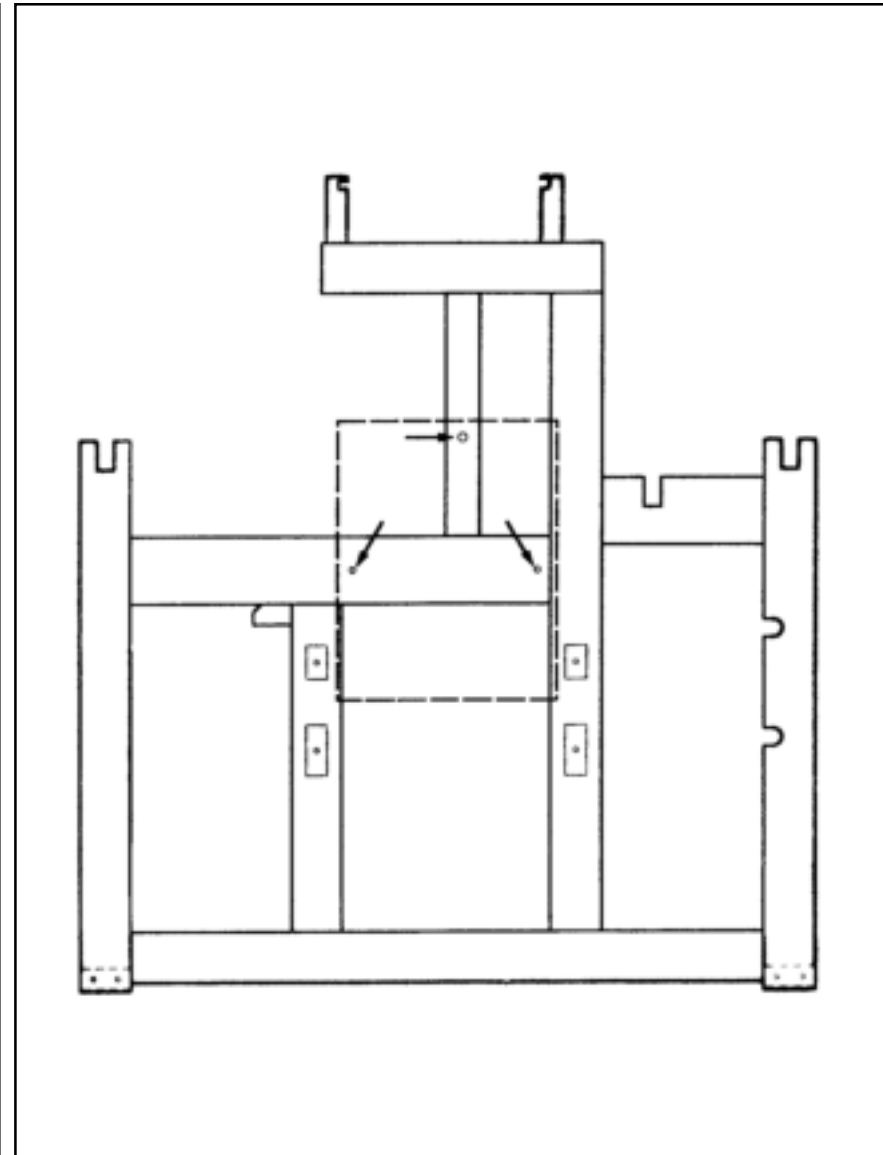

- 4.) Remove the nuts and washers from the mounting bolts and carefully slide the Dobby Head into position on the loom frame.

-
- 5.) From inside the frame, slip a washer onto each bolt end, then thread on a hex nut. Tighten with a 1/2" socket.
 - 6.) Find the Dobby Arm and check that the magnet is installed at the end. When orienting the arm, be sure that the magnet faces away from the loom.
 - 7.) Remove the hardware and wooden spacer from the pivot end of the arm.
 - 8.) Slide the Dobby Arm into the large window in the left side of the Dobby Head. Push it through until the magnet end sticks an inch or two through the slot on the right side of the head. Don't worry for the moment about cable alignments — we'll straighten all that out later.
 - 9.) Use a 1/2" socket to bolt the Dobby Arm into the Front Mid Horizontal.
 - 10.) By hand, move the Dobby Arm up and down. Check that the magnet clears the Dobby Arm. If not, loosen the screws on the sensor and adjust it so that the magnet clears.

HARNESSES ASSEMBLIES

It's time to add some of the muscle and sinew to your loom: the harness cables, harnesses, and harness springs. If you ordered your loom with Texsolv heddles, you'll need to assemble your harnesses now. Please follow the directions below. If your loom is equipped with metal heddles, proceed immediately to step #1 of the harness installation instructions.

MAKE TEXSOLV HARNESS ASSEMBLIES

- 1.) Locate the HARNESS STICKS, HARNESS WIRES, and Texsolv heddles.
- 2.) The sticks are divided into two groups: the top sticks have hooks that are spaced closest together. The hooks in the bottom sticks then, are farthest apart.
- 3.) Select one top and one bottom stick. Lay them on a table top parallel to one another, about 12" apart. Orient them so that the hooks point top and bottom.

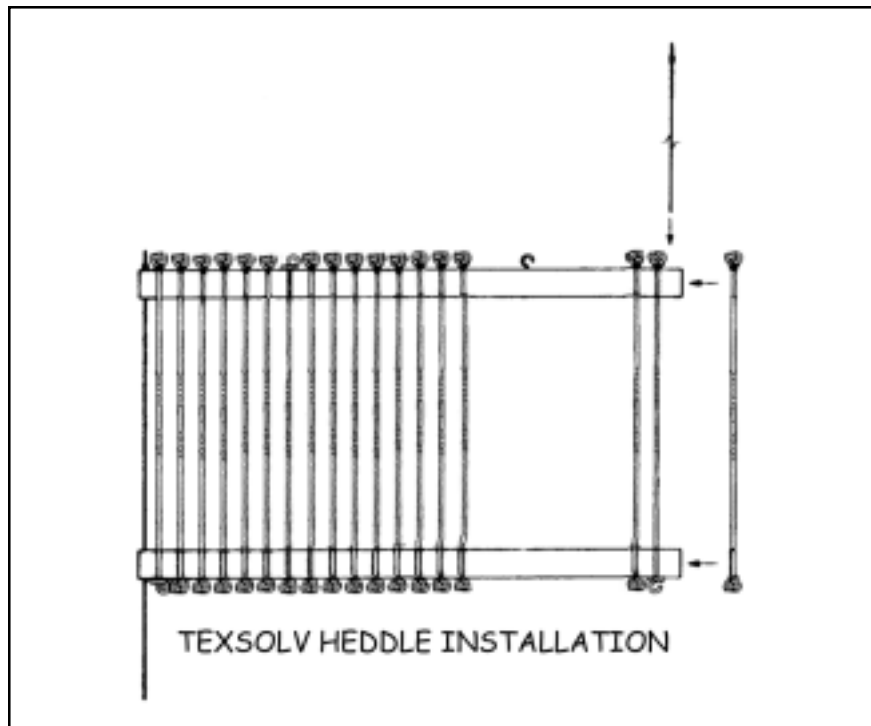

INSTALL THE HARNESES

- 1.) Please locate:
 - Harness Frames (if metal heddles)
 - Harness Springs
 - * The Harness Pulley Box has a top that slides out to give you access to the pulleys.
 - 2.) Your Dobby Head sports a long mane of bundled cables. Please remove the twist ties now and separate them. You'll see that each cable has two terminal ends, a long and a short. Select the first cable, front or rear.
 - 3.) Now, draw the cable up and over the three pulleys that are aligned with it. The longest end of the cable should hang over the pulley furthest from the Dobby; the shortest leg over the pulley in the between set.
 - 4.) Check that the cable is not twisted on itself — this will cause problems when you are weaving.
- 4.) Select two HARNESS WIRES and slide one through the end hole of the top stick so that the copper fitting at the end of the HARNESS WIRE is at the top. Insert the blank end of the wire through the end hole of the bottom stick.
 - 5.) Thread 25 heddles onto the sticks from the open end of the harness assembly (we provide 25 heddles per harness, plus 200 extra).
 - 6.) Add the second HARNESS WIRE.

Harness System

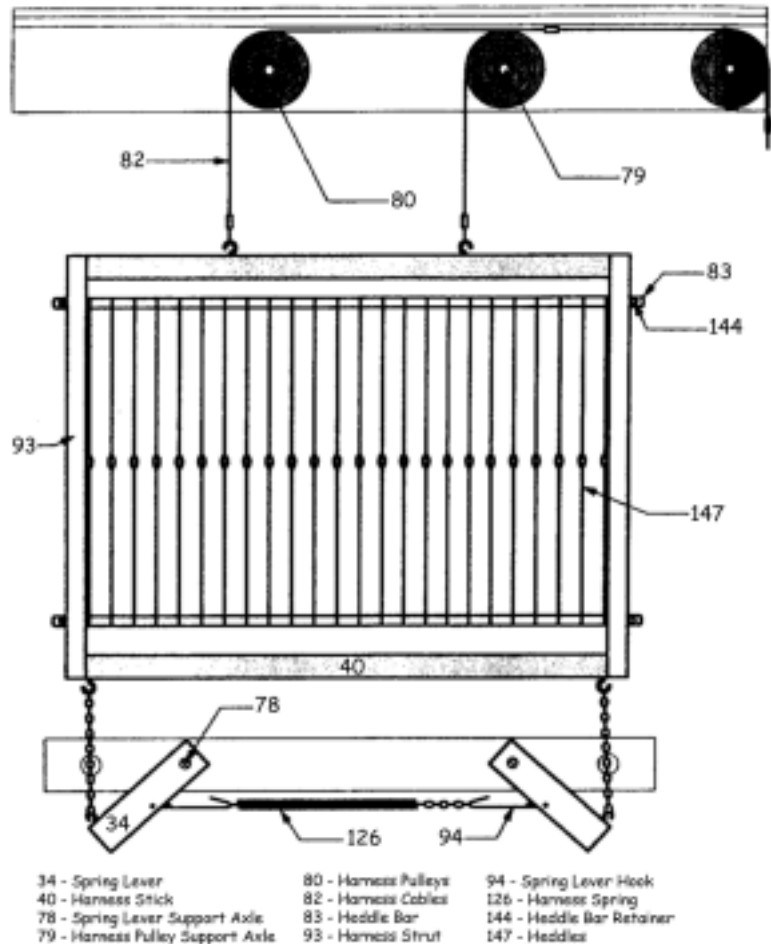

- 5.) Select a harness frame (metal heddles) or harness stick assembly (Texsolv heddles). Either assembly will have two hooks, top and bottom. The hooks that are set closest together are at the TOP of the assembly.
- 6.) Hang the harness assembly from the cable you just installed.
- 8.) Locate a harness spring. Each of these springs has a chain worked into one end. You will fasten one of these spring and chain assemblies between each set of spring levers (immediately below the harnesses).
- 9.) Find the corresponding set of spring levers. Each lever has a brass hook, which pivots on a brass pin. If the hooks are not already hanging free of their slots, pull them out now.
- 10.) Link the end of the chain into the hook in either spring lever, left or right. Attach the spring end onto the hook in the opposing lever.

-
- 11.) Lastly, hook the spring lever chains into the small hooks at the bottom of the harness. If you are using Texsolv heddles, the frames will be unstable until you completed this connection: managing them is frustrating, but certainly not impossible.
 - 12.) You've now installed one complete harness assembly. Go back and repeat steps 3 through 11 for each remaining harness. Check your work periodically; it's easy to connect the wrong harness into the wrong set of levers.

INSTALL THE WARP BEAM

- 1.) The loom is designed to carry two Plain Warp Beams or a single Sectional Beam. Plain beams may be used in either the upper or lower position, however, a sectional beam may only be mounted in the upper position.

If you intend to use two beams simultaneously, an additional assembly needs to be fixed to the Rear Verticals. We'll explain all that a bit later.
- 2.) If you are using a single beam, you'll likely prefer it in the upper position.
- 3.) Locate your Warp Beam and mounting hardware.
- 4.) Unthread the nuts from the ends of the RETAINER bolts.
- 5.) Slide each bolt through the mounting holes from the back of the Rear Verticals. Leave the top bolts a little shy of coming through.

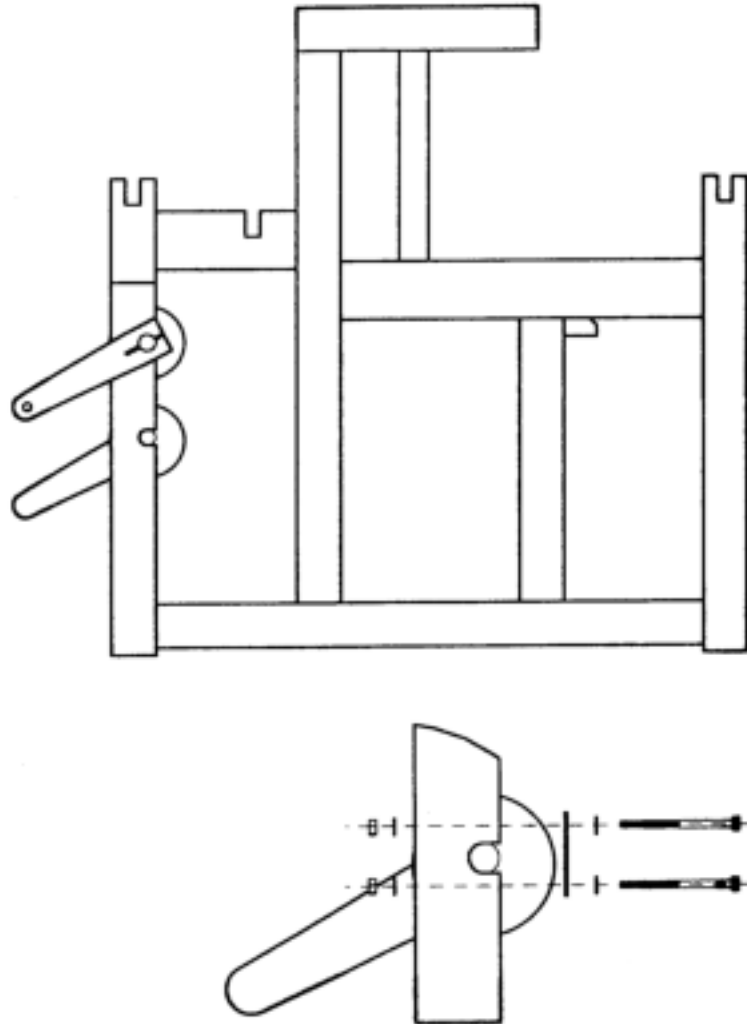

- 6.) Slip a retainer onto each of the lower bolts.
- 7.) Bring the warp beam into position. If you are using the upper location, orient the beam so that the long end of the axle extends to the left of the loom (opposite the Dobby Head).
- 8.) Seat the beam in the axle pockets and, holding the beam, rotate each retainer up.
- 9.) Slip the top bolts through the retainers, add the nuts, and tighten with your 1/2" socket.
- 10.) Locate the Warp Beam Handle and remove its hardware.
- 11.) Slip the handle over the protruding end of the beam axle, insert the bolt, and secure with the washer and nut. Note that the handle is connected with a carriage bolt, the head of which must fit into its stamped recess.

- 12.) The lower beam should be oriented so that the handle is on the Dobby Side of the loom. Follow the same procedure to mount a lower beam (but remember, you may only mount a Sectional Beam in the upper location).

SECOND WARP BEAM BRACKETS

- 1.) As noted above, if you intend to use two warp beams in your weaving, you'll need to attach an extra set of brackets to the Rear Verticals. These Warp Beam Brackets support an additional cross member which is used to direct your warp to the harnesses.
- 2.) Select the Warp Beam Brackets. They are identical, so you needn't be concerned about left and right.
- 3.) As shown in the diagram, these brackets bolt into the top of the Rear Verticals.

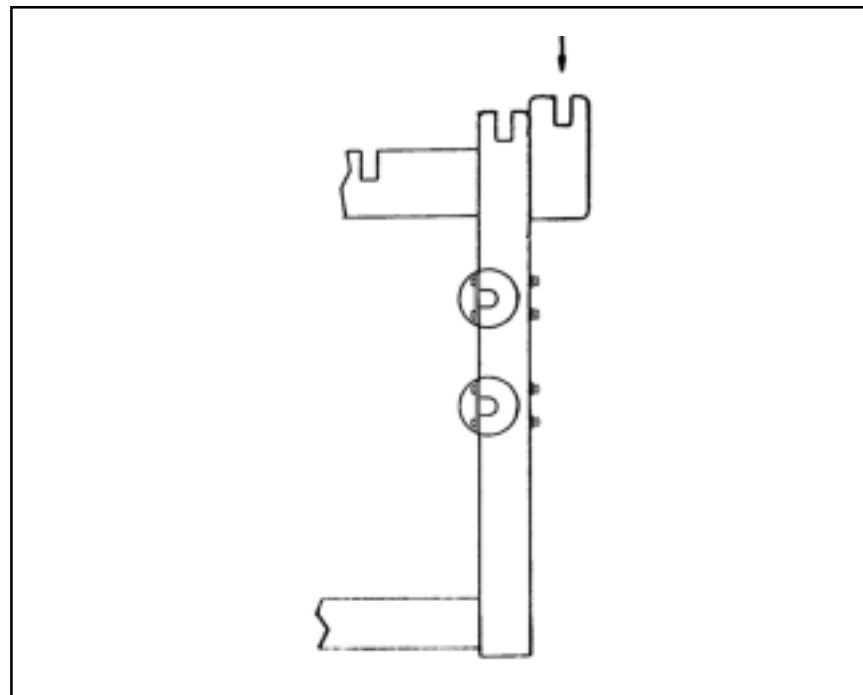

- 4.) Remove and save the two bolts that connect each vertical to the Middle Rear Horizontal.
- 5.) We've pre-positioned the bracket mounting bolts in the brackets. Remove the square nuts from the bolt ends, push the brackets into place, and tighten with a 1/2" wrench.
- 6.) You will have received an extra Breast Beam. In this case, it will act as a Warp Separation Beam. You may place it in the bracket pockets now or wait until you dress the loom.

MOUNT THE BRAKE CABLE SYSTEM

- 1.) You've already installed your Brake Pedal(s), now you need to add the cables and springs.
- 2.) Brake cables come in different lengths, depending on the type of beam you're using, and its location. Your cable assemblies are individually bagged and marked, but if you become confused, consult the table below.

Beam Type	Cable Length
Sectional	74 1/4"
Upper Plain Beam	51"
Lower Plain Beam	48"

- 3.) Select the poly bag with the appropriate cable assembly. It will contain:
 - Steel BRAKE CABLE
 - 1 — Tension Tie-Up with Toggle
 - 1 — "J" Bolt assembly
 - 1 — Eye Bolt/Cord assembly

- 4.) The accompanying diagram indicates the holes for the cable mounting hardware.

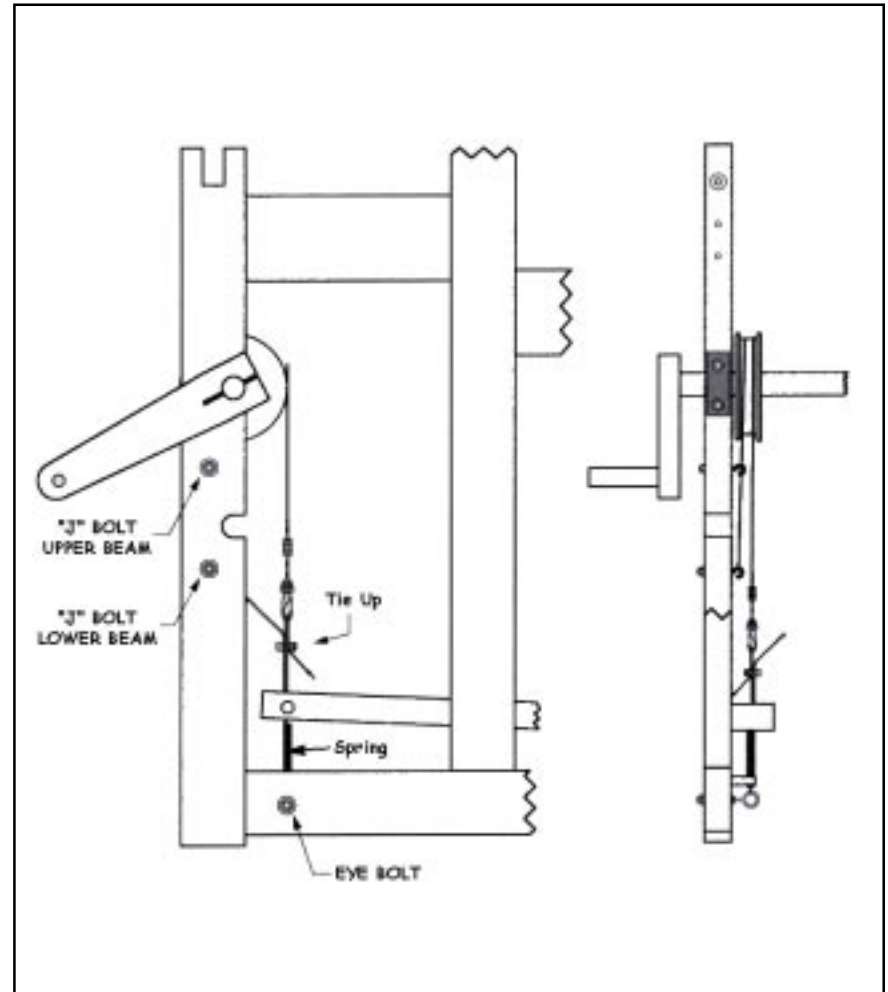

- 5.) Mount the "J" and eye bolts, making sure that each points to the inside of the loom. The "J" bolt should also point down.

- 6.) Use a 7/16" wrench to remove the nut from the bolt in the end of the brake pedal, then slide the bolt most of the way out.
- 7.) Get the tension tie-up (the dacron cord with toggle) and position it in the hole at the end of the brake pedal. You will be sliding the bolt you just removed through the tie-up so that there are three strands on each side with the toggle up.
- 8.) Push down on the end of the brake pedal so that you can attach the spring to the same bolt so you'll have the tie-up and spring on the bolt.
- 9.) Push the bolt back through the pedal and replace the nut
- 10.) Now find the cable. Connect the loop end to the "J" bolt.
- 11.) Bring the cable immediately up and around the BACK side of the Brake Drum. Wrap it several times around, taking care **not** to cross the cable on itself.

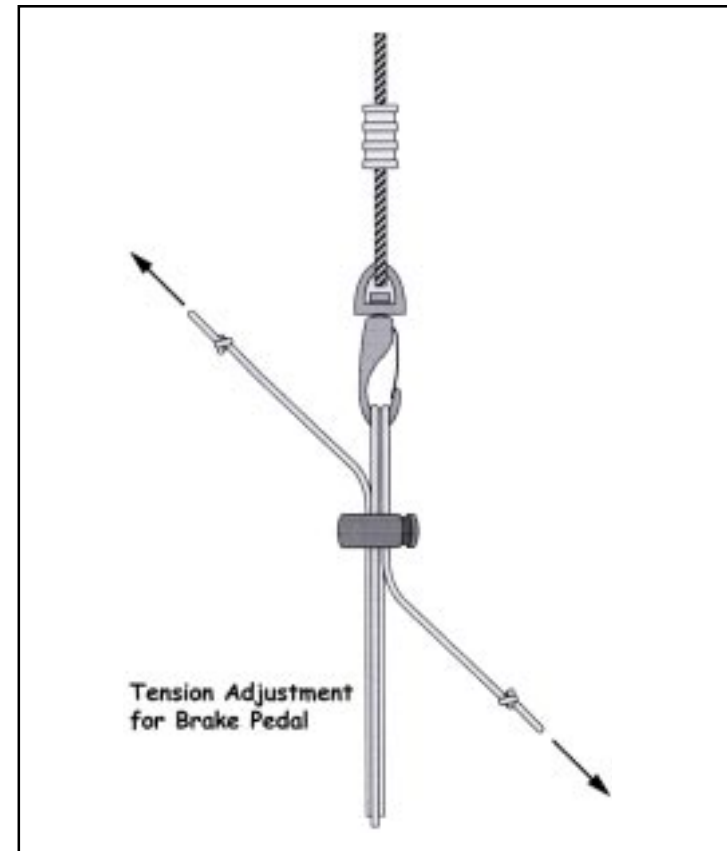

- 12.) When you've just enough cable remaining to almost reach the brake pedal, use the snap hook to clip the cable end onto the cording (three loops of the cord go into the snap hook). Slide the other end of the cording (three loops) through the large hole in the brake pedal. Then hook one end of the spring to the cording and the other end to the eyebolt.

-
- 13.) Check again to make sure the cable isn't crossed on itself.
 - 14.) Use the toggle on the tie-up to adjust the tension on the pedal.

CONNECT THE RIGHT TREADLE CABLE

Unless you've already untaped them, you'll find two cables wound around the Dobby Cam Cylinder assembly. These connect to the Right Treadle and the Dobby Arm.

- 1.) Untape the left-most cable, the one that circumscribes the cam (that nautilus shaped part). You'll note that this cable runs through a small hole in the cam. The hole is directional and the cable **must** be threaded around the cam in the direction established by this hole.
- 2.) Take the cable end from the bottom of the cam, over the Right Treadle Pulley (but under the metal retainer), and down to the end of the Right Treadle.
- 3.) Bolt the cable into the hole at the end of the **Right** Treadle.

- 4.) Leave the other cylinder cable taped down for the moment. You'll eventually connect this to the Dobby Arm.

CONNECT THE LEFT TREADLE CABLE

- 1.) The **Left** Treadle Cable is likely hanging out the bottom of the Dobby Head. As with the Right Treadle Cable, it has an eye worked into one end. The other is finished with a small copper barrel.
- 2.) Conduct the eye end under the slender pulley at the right of the Cam Cylinder assembly, over the remaining Treadle Pulley, and finally to the Left Treadle. Bolt it in.
- 3.) Find the end with the copper fitting. You will see a small hole and a somewhat larger hole drilled through the upper surface of the Dobby Arm. You should also find a small bag with one plastic cylinder taped to the arm. Remove the bag and select a cylinder. This is a cable retainer.

- 4.) Push the end of the cable through the small hole in the Dobby Arm. Now take the retainer and push it onto the cable in such a way that you can pull the copper fitting into the hollow interior of the plastic retainer.
- 5.) From above the Dobby Arm, pull up on the cable and seat the retainer into the pocket drilled in the underside of the Dobby Arm. If you've done your job, you'll no longer be able to see the retainer and the cable end will be firmly connected to the arm.

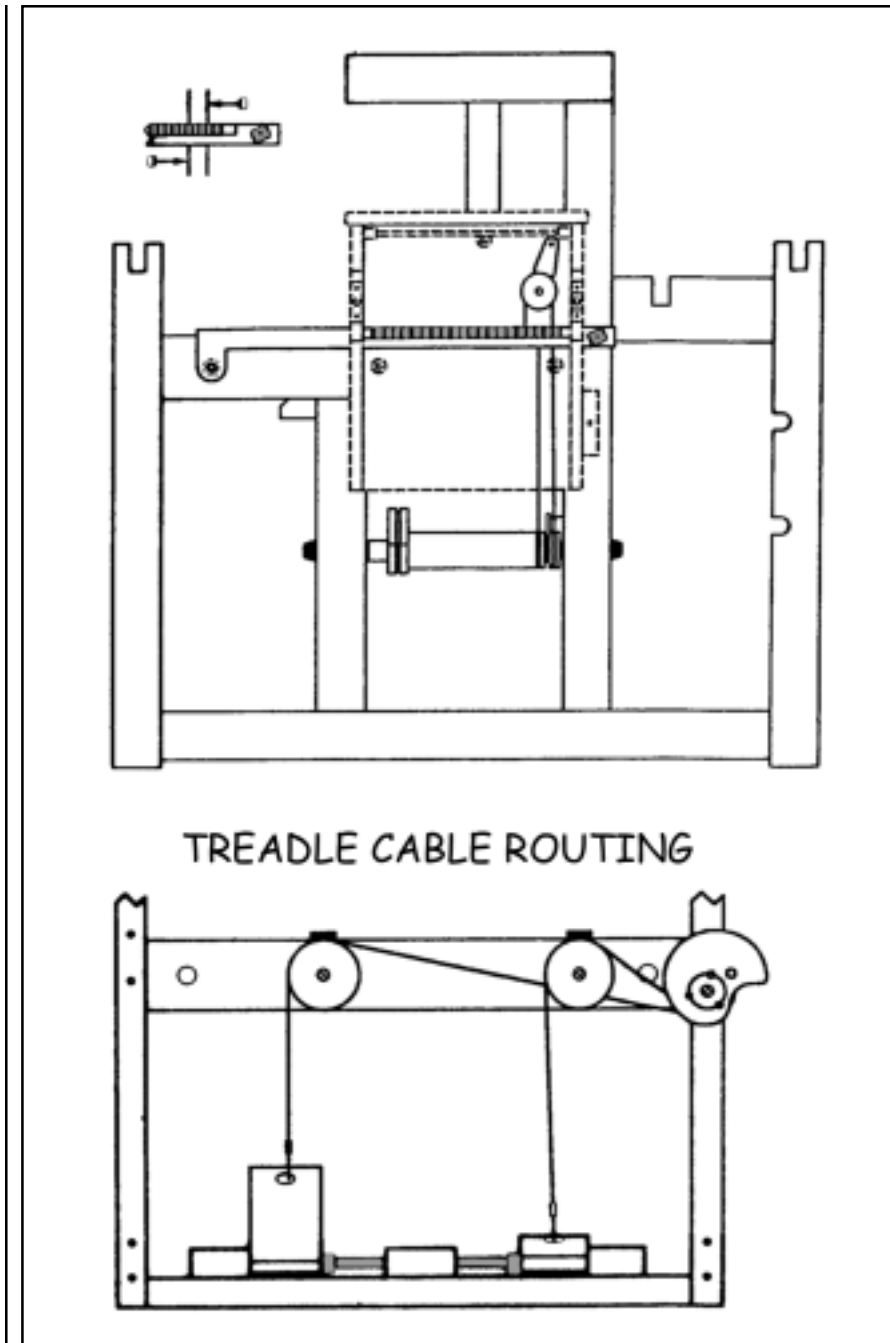

CONNECT THE CYLINDER TO DOBBY ARM CABLE

One last cable connection.

- 1.) Untape the remaining cable. It, too, comes out a directional hole.
- 2.) Wrap the cable around the cylinder and bring it up to the Dobby Arm.
- 3.) Same thing here. Insert the cable end from the bottom of the arm, up through the larger hole.
- 4.) Fix the second plastic retainer onto the cable end and seat it in the arm.

Let's check our work. The Left Treadle should hang about two inches below its pulley, the Right Treadle should nearly touch the floor. If this is not what you have, go back over the cable installation procedure and see if you can find the problem. Check, too, that the cables are properly located on their respective pulleys.

INSTALL THE SHELF

- 1.) You're nearly finished! -- time to install the shelf.
 - Orient the shelf so that the felt strips on the bottom will lay atop the three sets of harness pulleys when the shelf is in place. These act as cable retainers and will keep your Harness Cables properly located when you treadle.
 - Slide the shelf into the grooves in the Harness Pulley Supports.
 - Insert the Retention Pin into its hole. It will, and should be, tight. It will loosen over time.
 - If you cannot push the pin all the way into the shelf, check that you haven't put the shelf in backwards.

THE COMPU-DOBBY

There remains one last assembly operation -- the installation of your Compu-Dobby. No doubt you're extremely anxious to get a warp on the loom. This next part won't take much time or effort, but it does require precision so, if you're feeling at all fatigued, you may want to take a short break. When you return, we'll put the brains in the box.

GENERAL INFORMATION

- 1.) The Control Box on your loom is designed to sit atop the shelf. If you wish, you may actually locate it at a side table, provided the cables reach.
- 2.) We use the same Compu-Dobby on several of our looms and it has its own manual. You'll refer to this manual from here.

As you work through the directions, you'll find that some instructions are clearly written for other looms. This won't be particularly troublesome; the thrust of the procedure is clear and we'll already have done some of the operations for you. If you become confused at any point, please call our Customer Service number (888 893-0913) and ask for Compu-Dobby support.

- 3.) Once you've installed and adjusted the Compu-Dobby, secured the cables, and made the computer connections, return to these instructions and we'll see about getting a warp on your loom!

INSTALLATION

Now, open the Compu-Dobby box: find the manual: begin with *Install the Solenoid Box*. See you when you return!

WARPING THE PLAIN BEAM

If you have ordered only a sectional beam, proceed to the section titled “Warping the Sectional Beam”.

Various warping methods can be adapted to the AVL loom. However, we recommend the following method in which the warp is first wound on to the plain beam with the use of a raddle. Please study this method and try it. We have found that it aids in getting a uniform warp tension, especially when dealing with long warps.

CREATING TWO CROSSES

To begin, wind the warp on a warping board or reel. Make sure you put in two crosses:

- the threading cross
- the raddle cross

In the threading cross, each thread crosses the next thread in opposite directions. In the raddle cross, groups of threads cross each other. The number of threads in a raddle group can be determined by the number of ends to be placed in each section of the raddle or by the number of threads you are holding in your hand while winding the warping board.

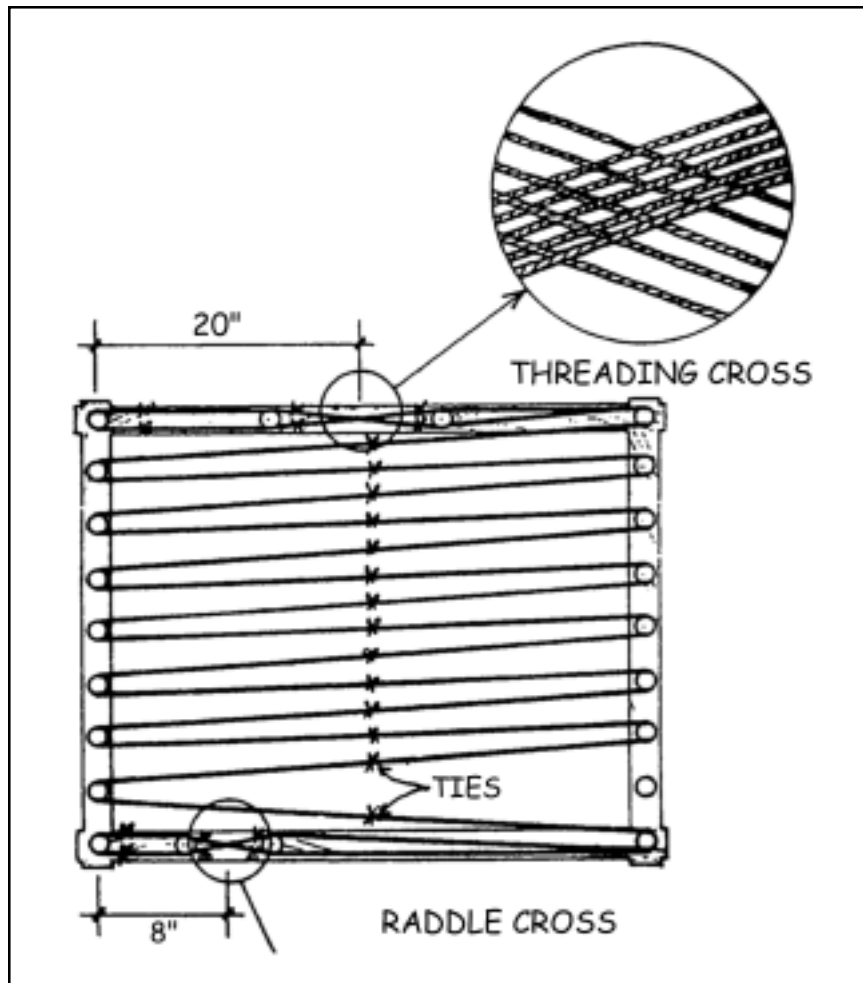

SECURING THE CROSSES

Before removing the warp from the board or the reel, secure the crosses. Use four ties to secure each cross. These ties go on each side of both pegs holding the cross.

It is usually a good idea to use different color threads for the ties on the tops of the pegs and another color to tie the bows underneath the pegs. By color coding your ties, you are less likely to twist the warp later.

REMOVING THE WARP FOR THE WARPING BOARD

Remove the warp from the warping board by chaining or by winding on the kitestick. Start from the threading cross and proceed to the raddle cross.

Since the capacity of the warping board is limited, for wide warps you will end up making a number of mini-warps and taking them off individually.

ADJUSTING THE TENSION DEVICE

Before winding on the warp, there are a few small things to take care of on the loom. First, check the tension device to make sure the rope is wrapped three times around the tension drum and that the rope end is clipped to the spring. This will prevent the warp beam from slipping backwards during winding and threading.

ATTACHING THE RADDLE

Now secure the raddle to the back of the loom. If you have an AVL raddle, simply slip it into the set of holes in the back of the rear vertical members.

WINDING THE APRON

Put your apron on the beam with velcro and wind your beam in the warping direction so that your apron is wound on the beam.

ATTACHING THE WARP TO THE APRON

Bring the apron around the separation beam and put the metal rod through. You can also put your warp section onto that rod or you can attach another one with the warp.

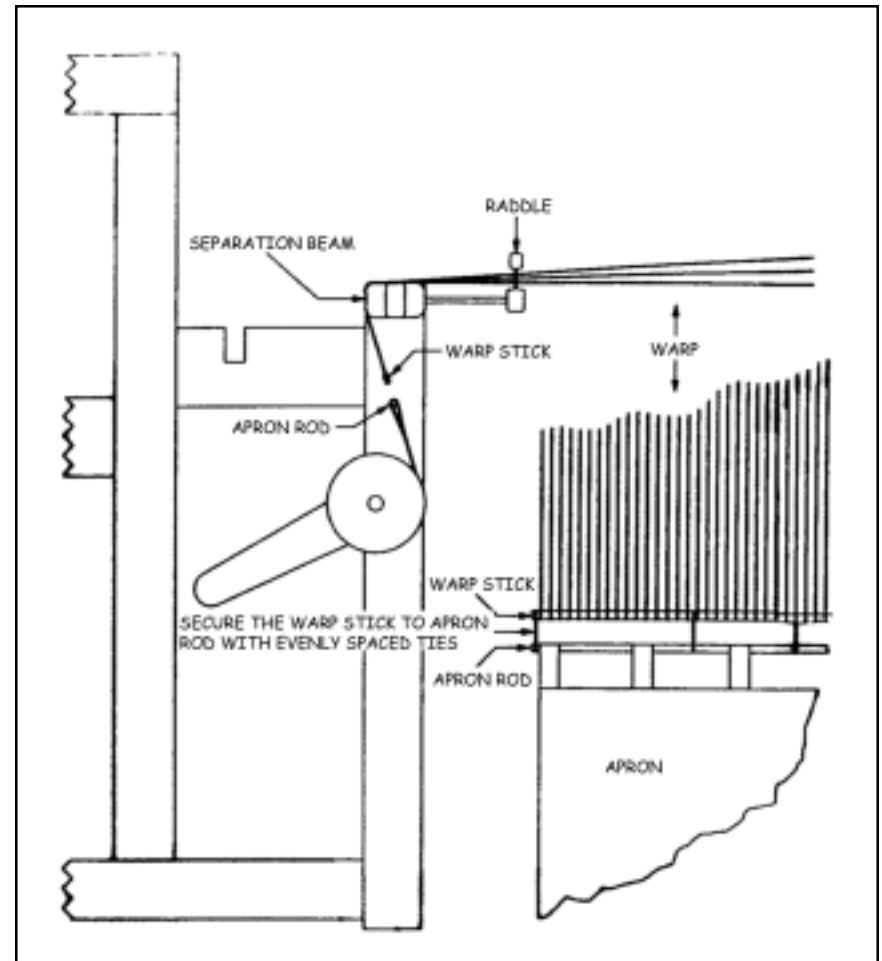

INSERTING STICKS IN THE RADDLE CROSS

Place two lease sticks in the raddle cross and secure together with string through the holes in the ends of the sticks. Now remove the ties from the raddle cross and spread the warp out on the sticks.

Measure the center of your raddle to use it as a center of your warp. The warp threads should either go through the middle of the raddle.

FEEDING THE RADDLE

To feed the raddle, distribute yarns through the raddle by dropping each raddle cross group into a dent in the raddle.

If you are using an AVL raddle with a sliding cover, slide it on after the raddle is threaded and secure it with two or three cord ties so it can't come off. Remove the raddle cross sticks when this is completed.

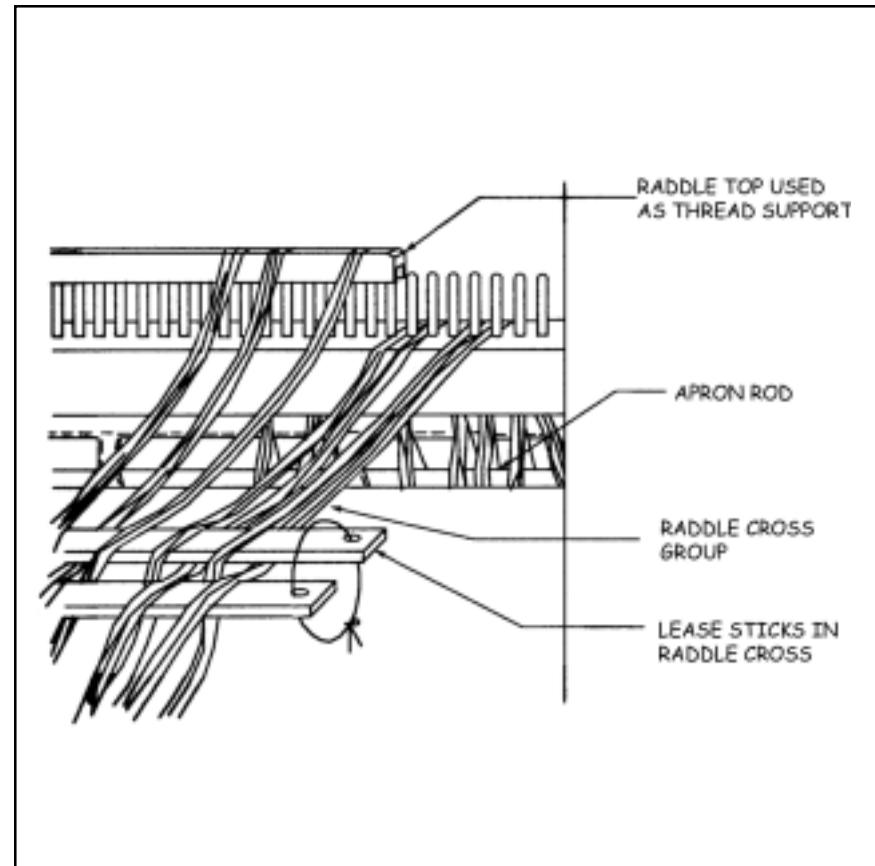

PREPARING THE PAPER

Prepare the paper for winding between the warp layers. Again, for the most professional results, and fewer tension problems, we suggest that the warp be as smooth, tight, and compact as possible. This would mean not using corrugated paper or sticks as they will make the warp too fat and/or lumpy. Corrugated paper is just too soft and the warp can never be wound tight enough with it. Heavy wrapping paper works well; seventy pound craft paper is good. If you are going to be using smooth, slippery warp yarns like fine linens or perle cottons, the edge yarns are going to need extra help in order not to slip off themselves. To do this, cut your paper four inches wider than the warp width and then fold over the edges an inch on each side. Be sure the warp is wound between the two folded edges not overlapping them.

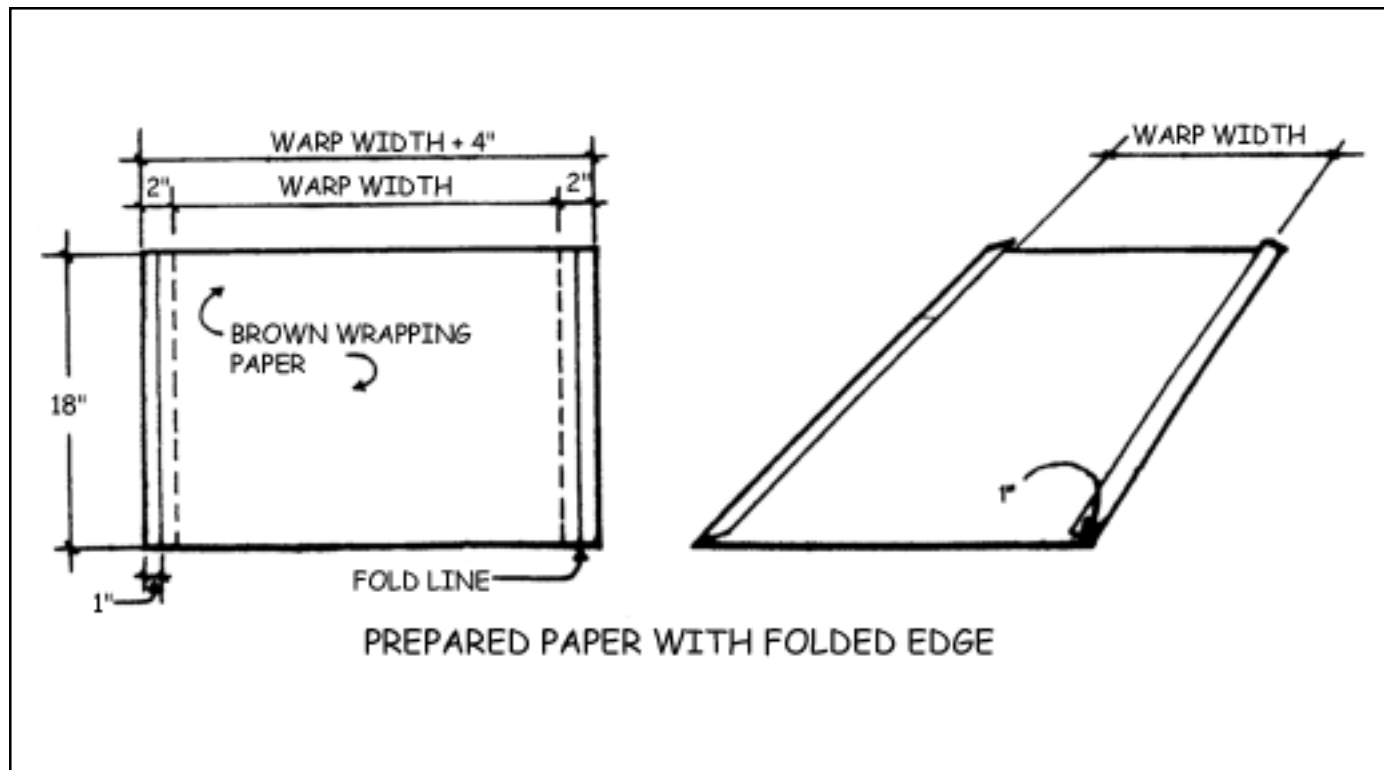

WINDING THE WARP

When winding the warp on from the back, i.e., with the warp spread out in back of the loom, turn the crank in a clockwise direction so that the warp comes in from the bottom.

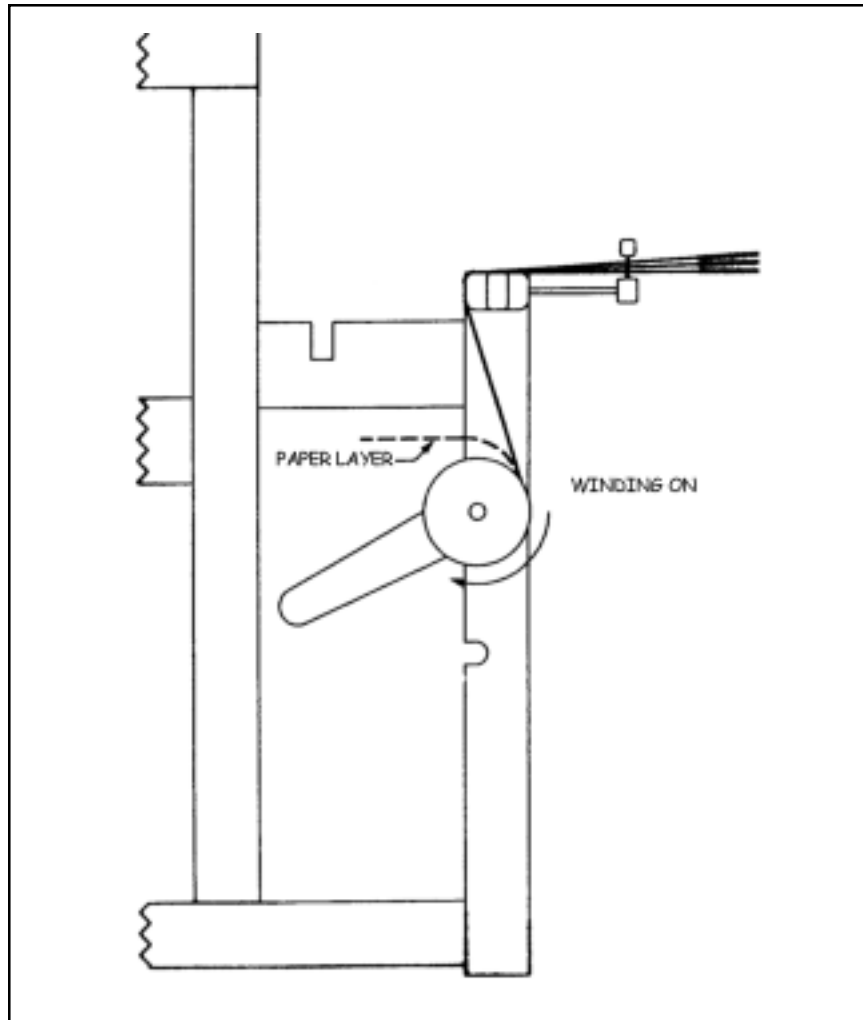

Remember, wind the warp on **tightly** under a lot of tension. This will vary with each warp material, but a good rule to remember is that the tension of the wound on warp must be greater than the tension during the weaving operation. You will need one person to hold a warp under tension on the back and one person to wind the warp on the beam using a handle. The person winding the warp can also insert the paper. For a wide, heavy warp, several helpers may be required.

If you have to do it yourself, you can use the jerking method. Make one turn around with your beam crank and then go to the back of the loom and jerk one section at a time to make the warp that is already on the beam tight. The idea of this method is that the warp does not need to be under tension all the time, but the part that is on the beam has to be tight. Make another turn, go to the back of the loom and jerk all the sections again and so on. If you have a wide warp, you might need to do up to ten jerking motions after each turn.

THREADING CROSS

When you come to the end of your warp, insert lease sticks in your threading cross.

Now remove the ties from each individual threading cross and spread the warp out on the sticks.

REMOVING THE RADDLE

When the warping is completed, free the warp from the raddle. If you have an AVL raddle, first untie the security strings, lift the raddle top off, and remove the warp from the raddle. Afterwards, replace the top on the raddle and leave it in its place on the back of the loom if so desired as it will not interfere with the weaving process. Then be sure to bring the end of the warp around the separation beam so that it now travels into the loom.

TWO BEAMS

For those who ordered the second plain beam, it is wound in exactly the same manner as the first warp beam except if you put a second beam in the bottom position.

The loom is designed to carry two Plain Warp Beams or a Single Sectional Beam.

There will be times when you will want to use more than one warp, which can not be put together on one beam.

You will have to put them on separate beams or use some kind of separate tension systems.

WHEN DO YOU NEED TO TENSION YOUR WARPS SEPARATELY?

When weaving:

- Very different size yarns.
- Yarns with different stretching qualities.
- Different densities.
- Different structures.
- Supplementary warp techniques (because some warp threads do not interlace as often as others).
- A group of special yarns for selvages and borders.
- Loops, piles, or puckers like seersucker.
- More than one layer with different setts in each layer.
- More than one layer with a different pick count in each layer.

SETTING TWO BEAMS

If you are confident in setting one beam, it is just as easy to set up a loom with two beams. It might take twice as much time and you do need to be more careful not to mix sequences.

- Wind each warp on the beam the same way you would do it if there were only one beam on the loom (plain or sectional). Make a cross and have a pair of lease sticks with a cross in each warp.
- See enclosed picture for warp routing.
- Proceed with a threading as if you only had one beam/ one cross, following your threading instructions and taking special care of which thread from which pair of lease sticks comes next.

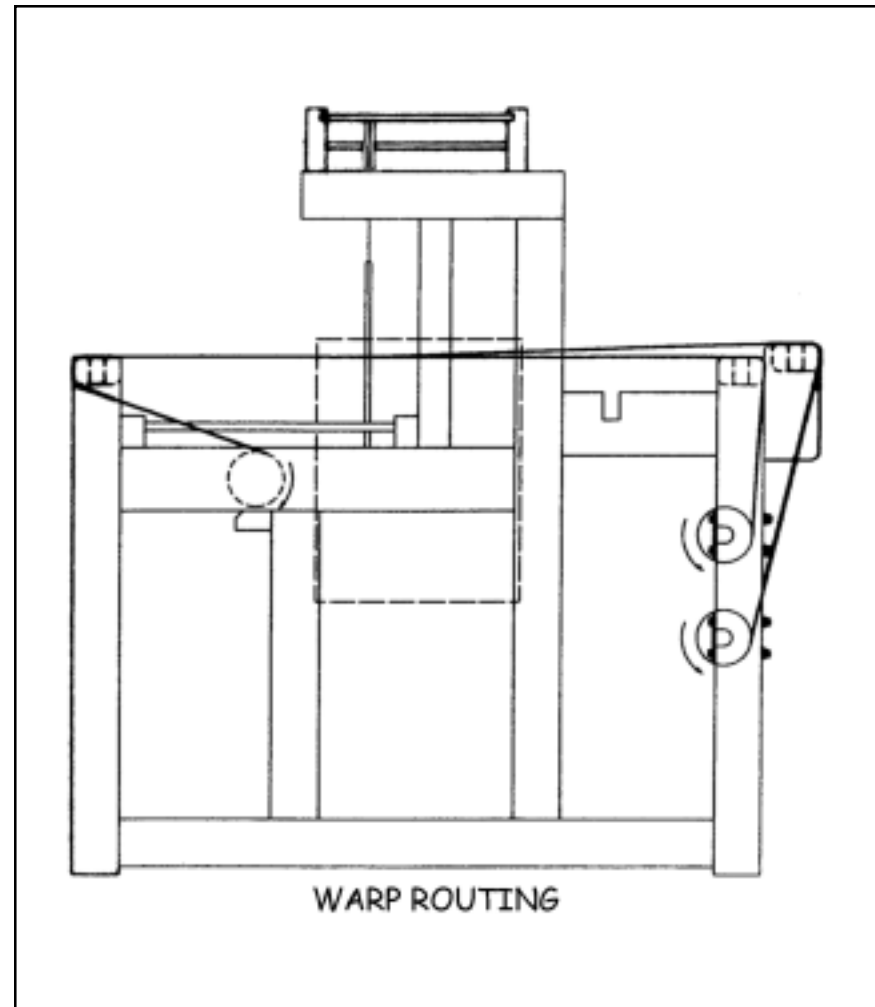

MORE THAN TWO WARPS, SEPARATE TENSIONING

If you have more than two warps to set and not more than two beams, you need to weight/tension your additional warps separately (do the same if you only have one beam and more than one warp to set).

- Make your warp sections on the warping board and take them off the board in a chain, on a kite stick, or just in a plastic bag.
Make sure that each bundle is not too thick. You will know when you need to divide each bundle if you feel that all the threads are not being tensioned evenly.
- The weight needs to have a strong loop of string on it so the warp bundles can be slip knotted into it. This makes it easy to undo the slip knot and move the weight when it climbs up to the back beam and must be let down again.
- The weight also needs to be adjustable. Plastic bottles with handles filled with water are perfect. You can also use fishing weights, washers, nuts, bolts ... They are not as easily adjustable like water bottles, but take less space. The lower to the floor you can hang them, the less often you need to reposition them.

WARPING THE SECTIONAL BEAM

The AVL sectional beam is designed to be warped in sections with the use of a tension box. The yarn travels directly from cones or spools which are mounted on a rack behind the loom, through the tension box, and onto the beam. Throughout the warping process, the tension box automatically keeps a constant and uniform tension on the warp. Not only does this system save time, but it makes it possible to wind on very long warps which would never fit on a warping board or reel.

SECTIONAL BEAM CALCULATION

First, you must calculate the number of spools or cones of yarn you will need. Each section is wound onto the sectional beam separately, therefore, you'll need to have one spool or cone for each end in that section (if your section is 2" wide, with sixteen E.P.I., that would be thirty-two spools or cones of yarn).

NOTE: It used to be that all sections were 2" wide. On an AVL sectional beam with metal pegs, you can decide to use 1", 2", or any number of inches sections. You can simply add more pegs in the pre-made holes or take them out.

To prepare for sectional beam warping, we need to calculate:

- how many spools we need to wind
- how many yards do we need to wind on each spool
- total yardage for the project

- **NUMBER OF SPOOLS?**

Sectional beaming requires the use of as many spools loaded with thread per individual section as your planned sett in the reed dictates.

To calculate the actual number of spools required, we need to know:

- how many EPI are we going to use in the fabric
- what **SIZE SELECTION** will we have to use in the fabric

If your warp is set at 24 epi per 1", you will need 24 spools for a sectional beam with 1" sections or 48 spools for a beam with 2" sections.

Therefore we can say:

OF SPOOLS = EPI x SIZE OF THE SECTION

- **TOTAL YARDAGE?**

If it is a single color warp or if a color sequence is repeating in each section, the same spools or cones can be used to wind all the sections needed for the warp.

TOTAL YARDAGE = # OF SPOOLS x # OF YARDS PER SPOOL

- **NUMBER OF YARDS PER SPOOL?**

To calculate the number of yards per each spool, we need to know:

- the **LENGTH OF THE WARP**
- **NUMBER OF SECTIONS** on the beam

We calculate the number of sections by dividing the **WIDTH OF THE WARP** by the **SIZE OF THE SECTION**. If the warp width is 40" and we are using 2" sections, our number of sections is 20.

All together, we can say:

**# OF YARDS PER SPOOL = LENGTH OF THE WARP
x # OF SECTIONS**

It is important to make these calculations in advance so that you can purchase your yarn in spools or cones corresponding to the amount of yardage needed on each. Sometimes this is not possible and you will need to wind your own spools from yarn that is in larger packages. For doing this, you will need empty plastic spools, a bobbin winder (preferably electric), and a yardage counter. These items are available from AVL.

EXTENSION CORDS

You might want to make a permanent set of extension cords to use when warping the sectional beam. Extension cords are also called apron cords and have the same function as the apron on the plain beam. They give you "reach" from the warp beam and allow you to weave every possible inch until the end of the warp touches the last shaft you are using. Make them out of a strong non-stretchable linen or cotton cord. You will need to make one extension cord for each section in your sectional beam. For each extension cord, cut a piece of cord. Take the two ends of the cord and knot them together. Measure to make sure that they are long enough to reach all the way to the harnesses. All extension cords should be exactly the same size.

When measuring the length of the cords, also check to be sure that when the cords are wound on to the beam, the end of the loop and any knots in the cords fall between the crosspieces of the sectional beam, not on them. A sectional beam is usually not solid. It is a frame that has metal pegs. That way you can keep the warp smooth on the beam without going over the knots of threads.

FEEDING THE SPOOL RACK

Next, place a spool or cone rack about five or six feet behind your loom. Place the spools or cones for the first warp sections on the cone rack.

Make sure you put each thread through the metal eye on the spool rack so the threads do not get tangled.

When arranging the spools on the spool rack, it doesn't matter whether you go top to bottom or bottom to top, the important thing is to be consistent in vertical columns and to place the spools in the order that the threads are in the warp.

Before winding the sectional beam, make sure to disengage the tension system so that the beam will turn counterclockwise swiftly. To do this, unlock the tension rope from the spring and completely unwrap the plastic cord from around the tension beam drum. Also, remember to remove the weight from the tension arm, if you have automatic tension on your loom.

POSITIONING THE TENSION BOX

On the beam on the back of the loom, set the tension box. That position will allow the tension box to travel from one section to another. The tension box is fastened to the separation beam with wing nuts. These can be released for the tension box to move. Once centered properly for a particular section, the tension box needs to be tightened again (for each section).

TENSION BOX

The tension box is an essential warping tool which:

- Puts threads under tension.
- Spreads threads to the proper width.
- Makes thread-by-thread lease.

TENSION BOX HEDDLE INSTALLATION INSTRUCTIONS

If this is your first time to use a tension box, you need to install heddles on the harnesses.

Your tension box is delivered with one bundle of one hundred heddles. These are held together with twist ties. Leave these on for now. Refer to the upcoming diagram to familiarize yourself with the tension box and its parts. Push down on one of the harnesses until it stops. This causes the other harness to go up. You will use that later for making a threading cross. Right now we'll need to use it to help in the assembly of the heddles to the harnesses.

- Remove the “heddle retainer” of the harness that is up, using a phillips head screwdriver.
- Notice there are four twist ties holding the heddles together. Separate the top two. Insert the top bar (of the harness that is up) into the space created by pulling apart the twist ties. Insert the bottom bar (of the harness that is up) into the space created by pulling apart the bottom two twist ties, making certain that the heddles aren't twisted. Now remove the twist ties.

- Count off fifty heddles and cut the loop at the top between the 50th and the 51st heddle.
- Now put the four twist ties back on the fifty heddles that were the last to go on the harness.
- Remove these fifty and reattach the “heddle retainer”.
- Now push down on the harness that is up, making the other harness come up.
- Remove the heddle retainer.
- Pull apart the top two twist ties and insert the top of the harness (which is up) into the space created. Pull apart the bottom two twist ties and insert the bottom of the harness into the space created.
- Reattach the heddle retainer.

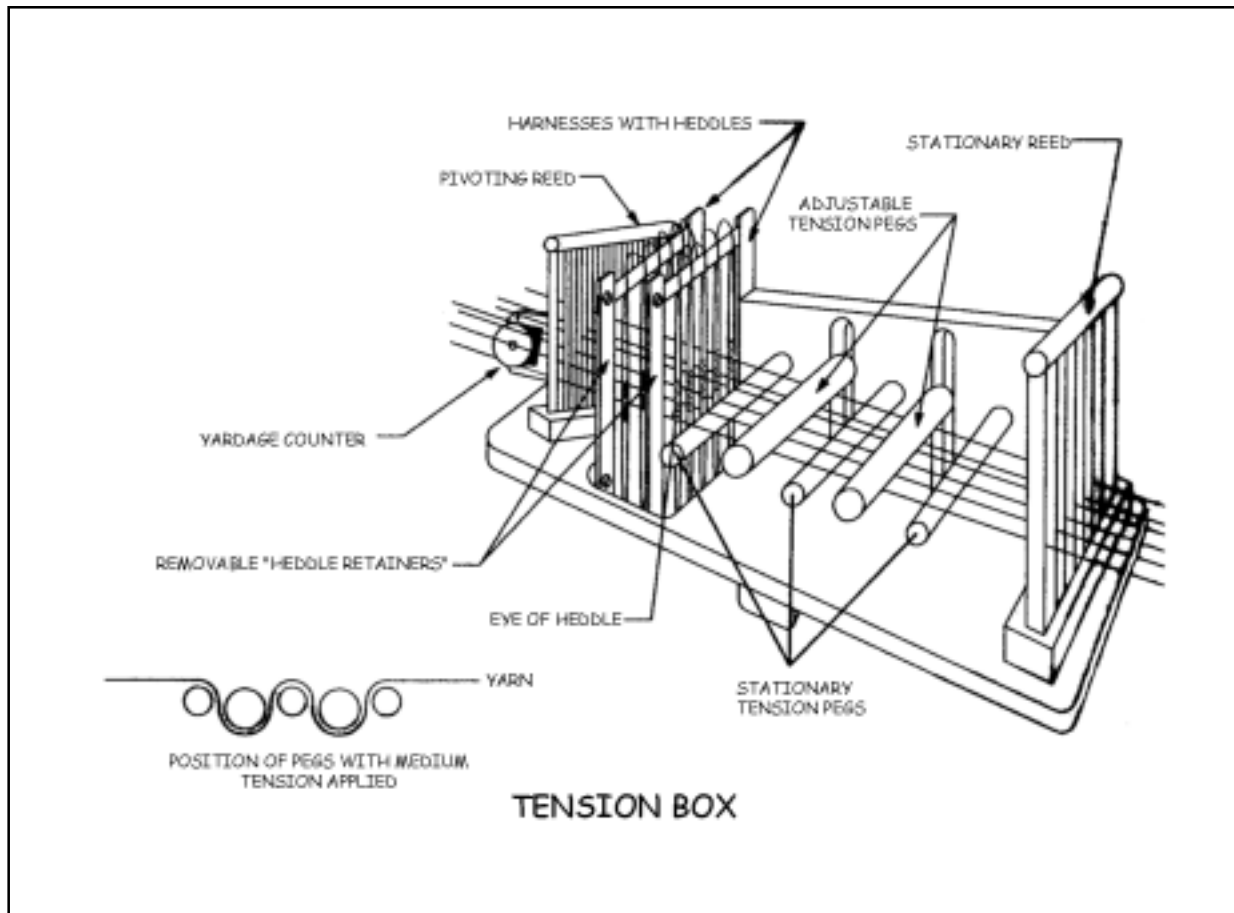

THREADING THE TENSION BOX

The best way to thread the tension box is to take one thread from the cone rack and thread it all the way through all the parts of the tension box, then the next thread all the way through. It works best to use the threads from the rack in a vertical order rather than a horizontal order.

Now let's go through the sequence for threading the tension box. First, move the two adjustable tension pegs up above the stationary pegs or remove them completely. Now sley the thread through the rear (stationary) reed section using a sley hook. Since this reed is eight dents per inch, you will divide the E.P.I. into eight to find out how many ends will be in each dent (with sixteen E.P.I., put two ends in a section). If your E.P.I. does not divide equally by eight, you can either vary the number of ends in each dent (with twenty E.P.I., alternate two and three ends in the dents) or thread the dents a little wider than two inches (with twenty E.P.I., put two ends in each dent; with forty ends, the reed will be sleyed 2 1/2" wide).

Next, bring the thread straight through the tension peg section in-between the larger adjustable tension pegs and the smaller stationary pegs or just above the smaller stationary pegs if you have removed the larger ones.

Next, thread the end through the two sets of heddles. The first thread goes through the front set of heddles and the next thread goes through the rear set of heddles. Repeat this alternating heddle threading for the rest of the ends. The heddle system will be used later to create the threading cross.

Now thread the end through the front pivoting reed. Here you have a choice of using an eight dent or ten dent reed. Pick the one that can be sleyed evenly and as close to the desired section width. If you can not get the exact width of the section, sley your reed slightly wider. This will make it just slightly wider than the space between the pegs. The section will be narrowed down by pivoting the reed. Never sley the reed narrower than the section on the beam. There is no way to expand it. After the tension box is completely threaded, the larger pegs are moved downward to apply tension. The further down they are moved, the more tension will be applied to the yarn. This is an adjustable system as different yarns require more or less tension. With a heavy wool the pegs may only need to be moved half way down, whereas with a fine silk, the pegs may need to be moved all the way down and the yarn wrapped an extra time around one of the stationary pegs to get the proper tension. Once you have adjusted the tension correctly, do not change it during the winding of the beam, as long as you are using the same type of yarn.

Once the tension box has been threaded, it is not always necessary to rethread it. If you need to change spools or cones, simply tie the new ends on to the old ends just before the rear stationary reed, then gently pull on the old ends until the new ends have come all the way through the box.

POSITIONING THE SEPARATION BEAM

To adjust the direction of your warp that travels from the tension box to the beam, remove the breast beam from the front position and place it in the mid-horizontal notch (see the illustration below).

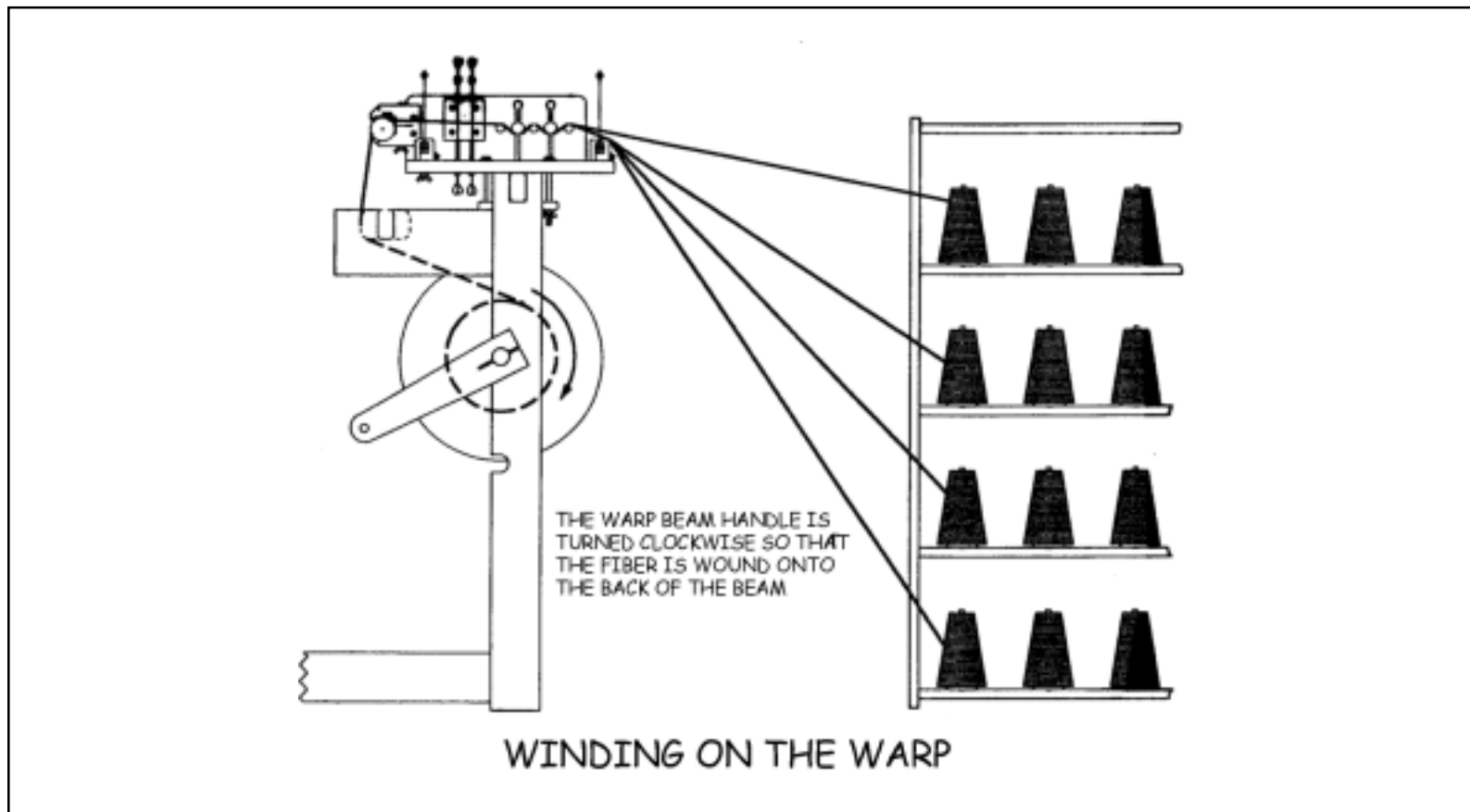

WINDING THE WARP

Before you start winding the warp, attach the extension cord to the beam and the section of the warp to an extension cord, tie an overhead knot in the warp threads from one section and slip that knot into the opening of the larkshead knot you created in the extension cord.

Pull it tight.

ADJUSTING THE SIZE OF THE SECTION

Line up the tension box approximately behind the section you will be winding. Now wind about one yard onto the beam. As you wind, you will need to fine tune the placement of the tension box along the track. When it is centered properly, tighten down the wing nuts under the tension box. At this point, you can pivot the “pivoting reed section” so that the yarn comes close to, but doesn’t quite touch, either the peg to the left or the peg to the right. Now tighten the wing nut under the pivoting reed. This shouldn’t need to be readjusted until you are using yarn of a very different size.

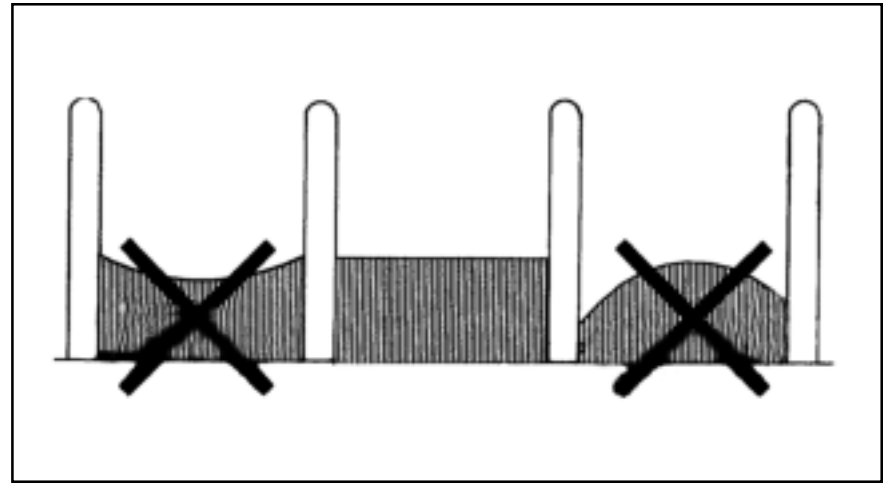

Extra care to correctly center and adjust the width of each warp section will result in more perfect tension while weaving.

Make sure that the threads are going on to the beam in flat layers. If you notice that warp piles up at the pegs, the section of the warp is too wide. If the warp falls down at the pegs, the warp section is too narrow.

If any of the above is happening, go back and pivot the front reed on the tension box again until you get perfectly flat layers. This is very important, otherwise you will end up having different length threads in one section, since the circumference of the beam within the section is not going to grow evenly. Therefore, you will end up having lots of tension problems.

COUNTING TURNS OR YARDAGE

To determine the length of the warp you are putting on the beam, you need to count either turns, revolutions, or yards.

To count turns, you can do it in your head, but it is more reliable to use a digital or mechanical revolution counter.

Counting revolutions even with a digital counter will still give the approximate warp length only, because the circumference of the beam will increase slightly with each rotation. This is called beam build up.

To count yards with a yardage counter while warping the sectional beam, you need to place the yardage counter at the front of the tension box. You should use an extra thread for measuring yardage, because if you use one of the threads from your warp section, that particular thread would have a different tension once you start weaving. The extra thread you use for measuring purposes only can be reused for each section.

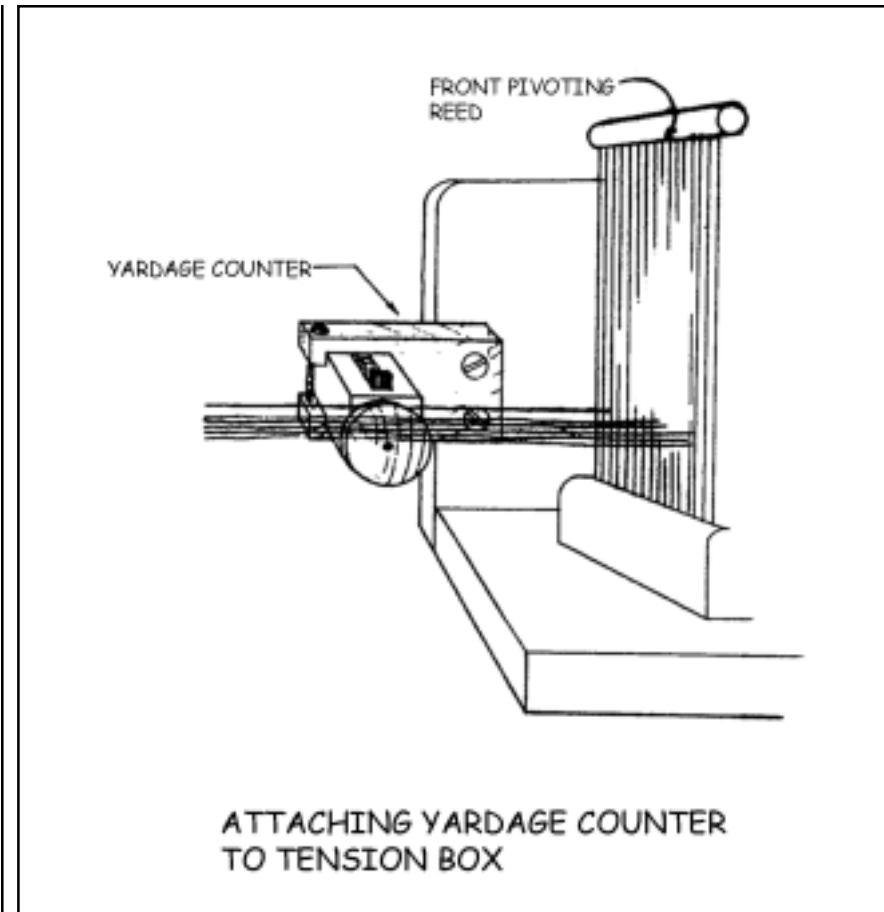

CREATING THE CROSS

When there is about a half yard left to be wound onto the beam, it is time to make the threading cross. Simply push on the rear heddle frame of the tension box, making half of the threads go up and the other half go down.

Now slip in an eight inch piece of contrasting thread (called a marking thread) through the opening (called a shed) created between the threads above and the threads below. Locate this marking thread about half way between the tension box and the separation roller.

Now push on the front heddle frame, making the other half of the threads go up. Now take one end of your marking thread and bring it through this shed. The two ends of the marking thread should now be together. Tie them in a bow knot. Wind the rest of the first section on, cut the ends, and secure to the wound on thread using a rubber band over the pegs.

Continue winding all the sections in the same manner by moving the tension box along its track.

INSERTING STICKS IN THE TREADING CROSS

When all the winding is complete, remove the rubber bands, unwind a few feet of warp, and slip one lease stick through the path created by the upper portion of each marking tie. Now slip another lease stick through the path created by the lower portion of each marking tie. Secure the lease sticks together, leaving about two inches between them, using masking tape or string through the end holes of the lease sticks. Now bring the lease sticks, with the warp ends, around the separation beams, so that warp travels towards the center of the loom (harnesses). Remove the breast beam from the position behind the harnesses and place it to its original position on the front of the loom.

READJUSTING THE TENSION

Now tie the lease sticks on the side of the loom so that they are at eye level when you are in your threading position.

To keep the warp from slipping forward during the threading process, rewind the tension rope around the pulley and tension drum and clip the rope end to the spring.

COMBINING SECTIONAL AND PLAIN WARPING

If you are winding a very fine warp, say forty ends to the inch or more, and do not have or do not want to wind a lot of spools or cones, it may be more convenient to wind separate warp sections on a warping board or reel and go from there directly to the sectional beam. If you decide to do this, however, your warp will be limited in length by what will fit on the warping board or reel. If you choose this method, follow these steps:

- Calculate number of threads for each section on your sectional beam.
On the warping board or on the warping reel, make “baby warps” for each section on your beam (if you are using a warping board, you will be limited in length).
Make crosses at each end: raddle cross on one side and thread-by-thread cross on the other.
- Take the warp off the board or reel by taking off the thread-by-thread cross first.

- Put the warp threads from a first “baby” warp in the raddle, making sure that threads are spread evenly and that they are creating flat layers when wound on the beam. Put the raddle top on or secure warp threads with rubber bands.
Instead of a regular raddle, you can put a mini-raddle in place of the front reed on the tension box. In this case, the tension box is used only for guiding threads into the sections. You do not thread threads in the tension box through the harnesses nor through the back reed and you do not adjust tension with the pegs.
- Attach each baby warp to the extension cords and proceed as in regular sectional beaming procedure.
- Since you are not using the tension box for tension, be sure to keep it taut manually.
- When you come close to the end of the section, take the reed cover off and continue winding the rest of the baby warp.
- Secure that section to the beam and continue to the next one.

THREADING, SLEYING, AND TYING ON

PREPARATION FOR THREADING

To prepare for threading, tie the threading cross sticks in a comfortable and visible position for threading.

You may also find it helpful to raise the harnesses. To raise the harnesses, pull the dobbie arm down to the bottom of its slot. To secure the arm in this position, simply insert the wooden retainer block. On the bottom of the dobbie unit are 16 cable ends corresponding to the 16 harnesses or 24 cables for 24 harnesses. In turn, pull each cable end downward on each cable into its slot in the arm, thus raising the harnesses. Make sure to lower the harnesses again when threading is completed. Never remove the block while any harnesses are lifted as this will cause the harnesses to drop too rapidly.

It is helpful to remove the breast beam, the beater top, and reed for the comfort.

The important thing in threading is your comfort. Take the time to position everything so that your body feels at ease while threading.

THREADING THE HARNESSSES

Now we're ready to thread the loom. If you are right handed, it is recommended to start at the right side of the warp. Grasp one group of ends in your left hand and your sley hook in your right hand. Direct the "hook end" of the sley hook through the "eye" of the first heddle you need to thread. Pull the thread through (for example, if you had a straight draft on eight harnesses, your first thread would go through the eye of a heddle on the 8th harness. The second thread would be threaded through the eye of the heddle on the 7th harness, the third thread through the 6th harness, and so on).

UNUSED HEDDLES

After threading is complete, make sure that the unused heddles are all pushed to the far sides of the harness sticks between the screw eyes and the ends of the harness sticks. For balance, there should be approximately equal numbered groups of unused heddles on both sides of each harness. This is especially the case if you have PES heddles. In some cases such as a very wide warp with a lot of unused heddles on the ends of the harnesses, you may need to tie each group of unused heddles into a tight bundle with tie tapes or string to keep them from falling off the ends of the harness sticks or

you may need to take heddles off the loom. In the first six months of using a new loom with polyester heddles, the heddles stretch out to adjust to the harnesses, and the heddles on each harness get stretched out to different sizes. For this reason, we do not recommend removing heddles from the loom for six months. When heddles are removed, they should be marked so they can be returned to the same harnesses. For the same reason, once the heddles have been on the loom for awhile, it is not a good idea to switch heddles to different harnesses. Mixing them up once they have been stretched would affect the evenness of the shed. What some weavers do with wide warps, in order to avoid having to take off extra heddles, is to distribute the unused heddles among the threaded heddles as the threading is taking place.

SLEYING THE REED

Now sley the warp ends through the reed. Some weavers start from the right side; some from the left; some in the middle. But, in all cases, be sure to measure accurately before starting so that the warp will be centered in the reed (or offset four inches to the right if the warp on the beam is already offset). Weavers have various ways of positioning the reed for sley.

TYING ON TO THE APRON

Now that you have your warp ends ready to tie, we need to prepare the apron. The ends will be tied to the apron rod.

Notice that the apron has two hemmed ends. One end has openings in it and the other end has a velcro strip. Take the end with the velcro and secure it to the cloth storage beam, making sure it is centered. Then wind the apron once around so that it holds itself in place. Route the apron up and around the cloth beam. Spread it out flat and center it over the cloth beam and insert the metal rod into the hem.

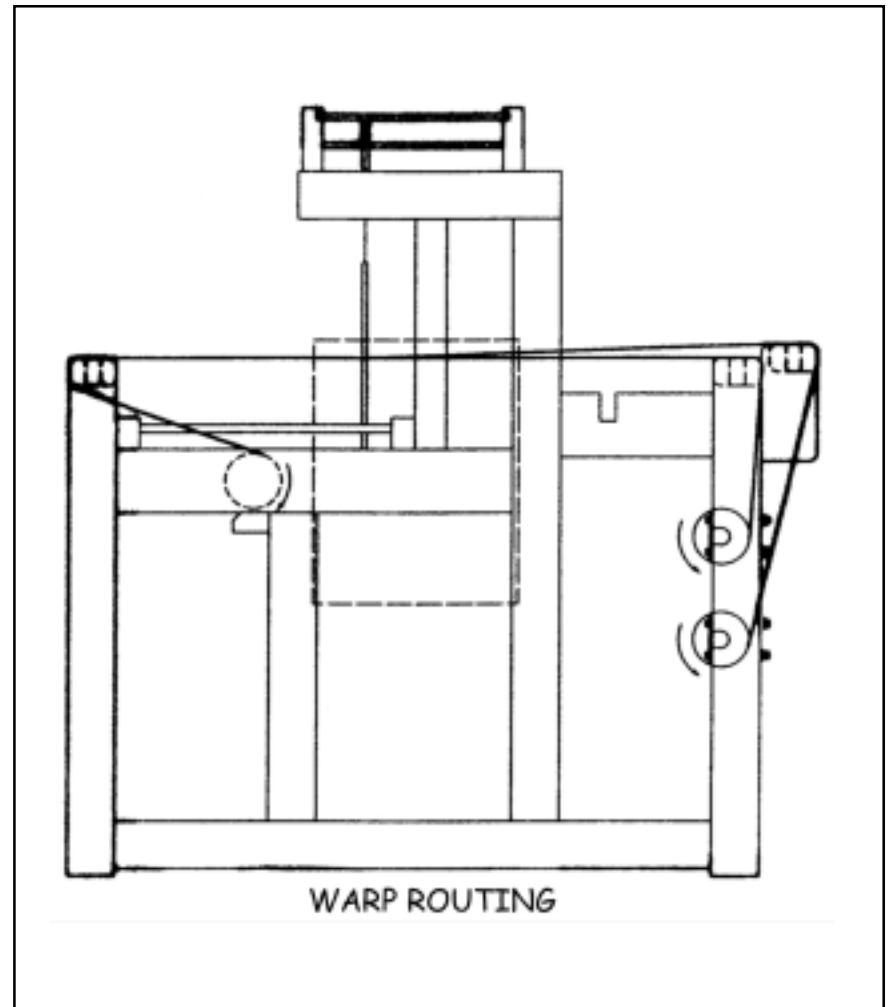

Now tie the ends to the metal rod. Starting from the middle, bring a first bundle toward you over the apron rod, then around and under it. Divide it in half and bring one half up on each side of the bundle. Use the ends to tie a surgeon's knot. It is the same as the first tie you make tying a shoelace, except you loop the end through twice. This kind of knot is very good for readjusting the tension.

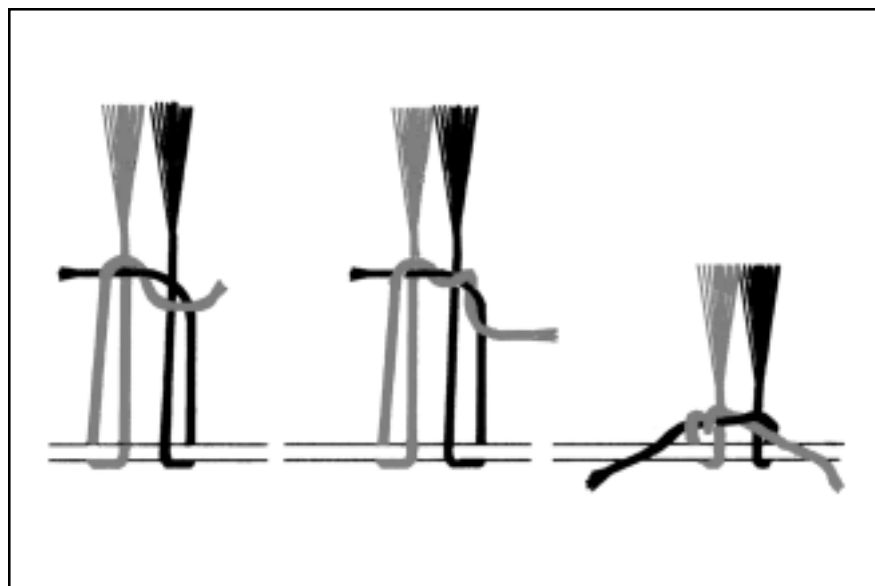

Start with one section in the middle, then the far right and the far left outside ones. Work your way in.

By now, the sections that were tied first are quite a bit looser than the ones tied last. To correct this, you do not need to untie the knots, simply grasp the ends and pull them away from you, then re-tighten the knots. Repeat this until all of the section are at approximately the same tension.

TYING ON TO AN OLD WARP

A new warp can be tied on to an old warp, thus eliminating the threading and sleying process, if the new warp introduced into the loom uses the same threading pattern and E.P.I. as the last warp. This process is especially good for production weavers as it saves time. It also takes less concentration and there is less chance of making mistakes in threading.

The tying on process starts when you are finishing the last warp on the loom. Before you cut off the fabric, make sure to leave enough unwoven warp to extend one foot behind the harnesses, through the heddles, and about six inches past the reed when the beater is in its rear position. Now open two opposite tabby sheds and insert the lease sticks into these sheds **behind** the harnesses. Secure the sticks together with tie tapes through the holes.

Now carefully cut the fabric from the loom and tie bundles of warp coming through the reed together so the yarn can't slip through. Cut the warp in back (leaving one foot past the lease sticks) and also tie bundles of yarn together for security.

After winding on the new warp on the beam, you can sit on a small stool placed in-between the harnesses and the back of the loom and tie corresponding yarns from the two sets of lease sticks together. An overhand or weaver's knot work well. This may seem slow at first, but you will work up a faster rhythm with some practice. A good goal to reach would be to tie 200 to 250 ends together an hour.

When all ends are tied together, go to the front of the loom and gently pull on the bundles of yarn going through the reed to pull the new warp through the heddles and reed. Then tie on to an apron.

LOOM CONTROLS

RIGHT TREADLE

The Right Treadle needs almost no explanation. It's the thing you use to raise the harnesses. Assuming your Compu-Dobby is active, and you've a peg plan in place, you simply push down on the Right Treadle and the selected harnesses raise. Relax and the harnesses fall.

LEFT TREADLE

Whereas the use of the Right Treadle requires no explanation, the function of the Left requires some very specific understanding. It is probably the most misunderstood mechanism on any AVL loom.

You might reasonably expect that, if the Right Treadle *raises* harnesses, the Left must help *lower* them. It doesn't — gravity and the Spring Levers bring the harnesses back down. The real function of the Left Treadle is to return the Dobby Arm to its proper reset position after each lift. If this is not done, harnesses will either drop or fail to lift altogether at the following lift.

If you remember nothing else of these instructions, please remember that you must **fully** depress the Left Treadle at each pick. It only performs its necessary function at the very end of its throw and will offer relatively little resistance.

CAM CYLINDER

The Right Treadle Cable is connected directly into the Cam Cylinder. This remarkable little rotating whizbang is one of Jim Ahrens' best ideas. When you treadle, you'll notice that the excentrically shaped pulley into which the cable is connected gathers and pulls cable around itself. As it does so it conveys mechanical advantage to the Right Treadle, making it easier for you to lift. You won't have much to do with the Cam Cylinder, but its good to know why it's there.

BRAKE SYSTEM

Studio Dobby Looms are equipped with a locking brake system. This means that the warp beam will be held absolutely captive — will not release warp — until you depress the Brake Pedal. It's fairly fool proof and affords very taut warps. When your fell has moved as far forward as you're comfortable, and you wish to advance your warp, depress the pedal and crank the warp forward with the Cloth Advance Handle.

You will have one Brake Pedal per warp beam and you'll need to depress them simultaneously if you wish to advance from two beams.

If you find that the brake cable is not releasing properly, even when you've fully depressed the pedal, you may need to remove the warp beam and lightly sand the groove in the brake drum (use 220# sandpaper or finer). In times of high humidity especially, the grain in the drum may raise and prevent the cable from slipping. Never, under any circumstances, should you apply wax, talc, or other finishes to the groove. The wood here needs to be raw for the mechanism to operate as intended.

If you remove the brake cable, please be sure when you reinstall it that the looped end is secured to the "J" bolt, that the cable is drawn immediately up from this bolt and around the back of the drum (x3), and that it then routes down the front of the drum where it connects to a spring at the pedal.

If the cable is installed in reverse the beam will not release when you depress the pedal.

CLOTH STORAGE SYSTEM

The Cloth Storage System consists of the Cloth Storage Beam (immediately in front of your knees), the Cloth Storage Apron, and the Cloth Advance Handle and pawl.

As directed in the preceding warping instructions, you'll secure the front of your warp to the Cloth Storage Beam via its apron. Use the handle at the right of the beam to advance the warp. Simply release warp beam tension by depressing the Brake Pedal(s), push the handle forward into the toothed ratchet, and rotate it down. It will draw the warp forward onto the beam. The pawl is that finger device that engages in the ratchet. It's job is to keep the beam from rolling backwards.

REMOVABLE BREAST AND SEPARATION BEAMS

You will have either two or three of these beams. They are interchangeable and, besides enhancing the structural integrity of the loom and giving you a convenient arm rest, serve to establish the warp in its horizontal plain. The beam at the front of the loom is called a Breast Beam; the beam at the rear, a Separation Beam. If you have two warp beams you'll need

two Separation Beams. Illustrations in the Assembly Instructions identify the mounting position of the second Separation Beam, if you have one. These beams can be moved to the interior slot to help with threading.

SLIDING BEATER

Here again, the action is obvious: the beater moves forwards and back on four precision bearings. To remove the reed, simply unthread the two nuts at the Upper Reed Support, pull off the support, and pull out the reed.

If at any point you feel that the beater is not running smoothly on its rods, you can easily adjust it: loosen the large screws in the four mounting blocks; bring the beater forward until it is equidistant from the Front Verticals at each side; retighten the front blocks. Do the same at the rear blocks, using the Castles as your reference point. The beater may require a little persuasion before it comes to square: please don't use a hammer anywhere in the adjusting process!

SWING BEATER

Some weavers are more comfortable with a Swinging Beater. Except for its mode of travel, it is the same as our Sliding Beater. You may adjust (rack) it by loosening the four bolts that attach it to its arms, bringing it fully forward and retightening. The Swinging Beater will not take a good adjustment unless a reed is in place.

SECTIONAL BEAM

If you are a sectional weaver, you'll be delighted with this beam. Because each of its hoops is removable, you may create sections of any width you like, provided they are in one inch increments. Tying on to the beam is explained in the section entitled: *Sectional Beam Warping*.

There are two things to remember: 1.) You may only use a Sectional Beam in the upper position; 2.) The loom will not accommodate more than one warp beam if you are using a sectional.

PLAIN BEAM

The Plain Beam is provided with an apron which will allow you to maximize the length of your warp. You may use two Plain Beams at a time, however, if you do so, please orient them so that the handle on the *upper* beam is to the *left* side of the loom and the handle on the lower is to the right.

DOBBY HEAD AND COMPU-DOBBY

The Dobby Head is that many cabled box hanging from the right of your loom. It works in tandem with the Compu-Dobby and together they provide the interface between your computer and loom. The operation of the Compu-Dobby is explained in its own manual and we won't reprise those instructions here. Suffice it to say that it is extremely important that you achieve and maintain a good adjustment of the Solenoid Box. If this device is out of tune, your harnesses will behave erratically.

These are the basic components on your loom. You've a world of weaving before you so best get started!

SPRING LEVERS

The springs of the spring lever return system should also be adjusted for positive harness return, i.e., the harnesses stay all the way down in the depressed position and require the least amount of effort for lifting. This will vary according to the weight of the warp. In general, lightweight, less dense, looser tensioned warps with a smaller weaving width will need very little spring tension to assure positive harness return. Heavier, denser, tighter tensioned, and wider warps will need more spring tension. To tell if the harnesses are returning all the way, open several sheds by working the treadles. Watch the unlifted harnesses and if the tops of their heddles become loose and tend to move around, then spring tension should be increased, but just enough to get the harnesses to stay down and no more or your treadling effort will be made greater than it has to be. Not all harnesses will need the same adjustment. It will depend on the distribution of your warp on particular harnesses.

To adjust the spring tension, simply unhook the spring and then rehook it one chain link shorter (see the assembly section). This tightens the spring and makes it pull down harder on that particular harness. Test the warp again by doing some more treadling and if more spring tension is still needed, try

one or more chain link less. Under unusual conditions (perhaps a very tight rug warp) two springs on some or all of the harnesses may be necessary. If all the springs are set the same, the back harnesses will have a looser tension than the front. This is because the back spring levers and their hooks are longer since the back harnesses travel farther when a shed is made. Accordingly, in some cases, the back spring levers might have to be adjusted shorter to give the same tension as the front ones. The important thing to remember is that the system is designed so that it can be “fine tuned” for each particular warp, so experiment with it. In general, for most medium tensioned warps, you will find that adjusting will not be necessary. The loom comes with sixteen chains and sixteen springs (or twenty-four chains and twenty-four springs). If extra springs are needed, you can use 16” screen door springs which can be purchased in almost any hardware store. You can also get extra chain there.

HARNESSES

Your AVL will have either polyester or metal heddles. The supporting harnesses (or shafts) are different for the two heddle types: metal heddles, whether twisted wire or flat steel, are suspended from rigid frames; polyester heddles are carried on transverse Harness Sticks, top and bottom. In all cases the harnesses are stabilized at the bottom by a series of spring-tensioned levers, Spring Levers. These hold the harnesses down and prevent your heddles from *floating*.

Some weavers like metal heddles because they believe they are easier to thread; others prefer the lighter and quieter polyester heddles.

On occasion you will find that one or more of your harnesses will misbehave. That is more likely to happen with harnesses with Polyester Heddles. There are a finite number of things that can cause these problems.

TABLE 1 / HARNESSES

Symptom	Possible Cause	How to Fix It
A) One or more top harness stick collapses ; it assumes a diagonal angle and one leg of the harness cable from which it is suspended goes slack.	1.) Your heddles are bunched together towards the center of the harness or on one side only. This is a problem because the heddles are part of the harness structure.	Move a few heddles to each end of your harness sticks; just to the inside of the harness wires that connect the top and bottom sticks. That way your harnesses will be balanced.
	2.) The harness cable supporting the shaft has come out of its pulleys at the top of the loom	Trace the cable back through its pulleys in the Harness Pulley Support and make sure that the cable is properly seated. Check the action of the Dobby Cable as well. Make sure that it moves easily up and down. If the Dobby Cable seems to bind, check for debris in the hole where it comes through the Dobby Top. You may need to use a very thin piece of wire to dislodge accumulated yam dust or other debris.

Symptom	Possible Cause	How to Fix It
B.) The heddles float ; they are lifted upwards by the warp thread when you tension the warp and your shed is not even or not large enough.	1.) The tension in your warp is greater than the tension in the springs that hold the harnesses down.	Take up a link or two in the chain that spans the Harness Spring Levers for that particular harness. Check the result and take-up more links if you feel you need more hold-down tension. Do not try to make all chains the same size. The size will depend on how much tension is required for each harness depending again on the number of threads going through that harness.
C.) One or more harnesses that are supposed to raise don't.	1.) Left treadle isn't being pressed all the way down.	Concentrate on getting both treadles all the way through their travel.
	2.) Dobby arm out of adjustment.	Realign the dobbie arm according to the assembly instructions.
	3.) Dobby cables out of finger slots.	Rearrange the cables according to the assembly instructions.
D.) Harnesses don't raise properly.	1.) Harness cables have been hooked to the wrong harness.	Rearrange the cables.
	2.) Chains from the spring levers have been hooked to the wrong harnesses.	Rearrange the cables.
	3.) Copper hooks on the spring levers have been bent.	Straighten the hooks with pliers.
E.) Harnesses jam up on each other.	1.) Heddles are not distributed evenly over the harness sticks.	Redistribute the heddles evenly on both sides from the center of the harness sticks.
	2.) Harness wire that connects the harness sticks has jumped out and got stuck in the heddles of the other harness.	Pull the wire out, make sure it does not catch any heddles, and replace it to just connect the top and the bottom harness sticks. If you have a large number of extra heddles on each side, you might want to tie them in bundles to prevent getting caught by the harness wires.

LOOM MAINTENANCE

1) TIGHTENING THE BOLTS

The single most important thing you can do to extend the life of your loom, and preserve its operation, is tighten the bolts that hold its frame together. These will loosen over time, due to changes in its environment and to your own creative exertions. A loom which is allowed to become loose-jointed will certainly cost you weaving time, perhaps affect the quality of your work, and definitely become older than its years.

Loom Parts	Lubrication and Cleaning
Shuttles, Shuttle Race, Single-Box Flyshuttle Picker Grooves	Paste Wax
Slide Rods (sliding beater rods, bobbin winder)	Steel Wool
Axles (pulleys, spring levers, overhead beater)	Silicon Spray
Warp Beam Metal Rods (where metal works against the wood frame)	Paraffin
Warp Beam Brake Drum	Sandpaper

2) LUBRICATION AND CLEANING

There are several mechanisms on your loom which will benefit from the occasional light application of an appropriate lubricant. Not all lubricants are suitable in the weaving environment. Machine oils and greases, for example, may provide

plenty of slick, but they also capture yarn dust and will, over time, actually impede the action of your loom.

3) **CLEANING A FILTER**

Unless you have an AVL Air Shuttle or other pneumatic accessory, you will have only one filter on your loom, and then only if you have a Compu-Dobby. This is the fan filter and it performs two functions: it cools the unit and it removes dust from the air before it is drawn into the fan.

4) **CHECKING CORDS AND CABLES**

Check those cords and cables. All machines wear, and cords are usually the first things that fatigue on a loom.

5) **TOOL KIT AND SPARE PARTS**

Here's a list of the basics, nice-to-have-around items:

a) **Minimum Tools**

- Socket wrench with
 - 7/16", 1/2", 9/16" socket
- 6" or 8" crescent wrench
- Medium standard blade screwdriver
- 4-1 Screwdriver or medium phillips and standard screwdrivers
- 1/8" allen wrench
- Paste wax
- 0000 steel wool pad
- 220# sandpaper
- Paraffin wax

b) **Spare Parts You Might Consider Having**

- Spare Treadle Cable (left/right)
- 6' length of 350# Braided Dacron Cord (for emergency repairs)

AVL CUSTOMER SERVICE

AVL offers free technical support to the original owner of all our looms. This means if you ever have a problem, you can call, fax, or e-mail us and we'll help you find a solution. Please take advantage of this service; your satisfaction is extremely important to us.

Customer Service Phone: (888) 893-0913

Fax: (530) 893-1372

E-Mail: info@avlusa.com

AVL WARRANTIES

Your loom carries a full warranty on parts and labor for two years from the date we ship it to you. Your Compu-Dobby is fully warranted for one year. If a part wears or breaks during this period, we will replace or repair it at our discretion, but at no charge to you.

AVL RETURNS POLICY

All goods, excepting software, may be returned for refund within thirty (30) days of the shipping date.

A 15% restocking fee will be assessed for all but defective items.

AVL will pay all shipping costs for defective items within the continental United States for the entire warranty period. Special provisions apply for the return of looms (please contact your sales person for more information).

AVL will generally return repair or replacement items via UPS Ground service. Additional charges for expedited shipping are the responsibility of the customer.